



# Components

Vibratory Feeders  
Feeder Bowls  
Linear Feeders  
Vibration Platforms  
Hopper Systems



# Welcome to RNA

As your leading partner for efficient high-precision and high-performance feeding technology, we offer a comprehensive range of feeding system components specially designed to optimize your production processes. With nine production sites and our international network of partners, we can serve your needs anywhere in the world. Our name has been synonymous with outstanding performance in terms of technology, quality and reliability for decades now. Our two business units include the development and manufacture of tailor-made feeding systems and their components.

Whether you are looking for customized belt feeders, hopper systems, bowl or linear feeders, vibratory platforms or controllers – RNA offers the most advanced solutions, tailored to your specific requirements. Our products are regarded as industry standard and stand for longevity, reliability and efficiency in a multitude of industries – from automotive via medical technologies to electronics manufacturing, to name but a few. Given our massive expertise in feeding technology, all components have been tried and tested in real-world production conditions and are renowned for their exceptional reliability and sturdiness. New findings are continuously being included in the further development of all components with a view to permanently enhancing our products.

We offer a complete range of powerful drives and controllers, as well as accessories, whose quality and functionality are generally recognized - also for tasks with special performance requirements. What's more, all our drives are digitized and can be digitally tuned by means of our specially developed "DigitalMotion" simulation software. This allows

you to perfectly adjust our drives already during the design phase of your system, saving you valuable time on the shop floor.

Our product portfolio is rounded out by excellent service, immediate delivery and high availability, specific designs for the pharmaceutical and food industries, as well as certifications to UL or CE standards. Prior to delivery, all components once more undergo extensive testing to ensure trouble-free operation. With more than 55 years of experience in automation and feeding systems, we are very proud to present innovative products with a commitment to technological excellence and sustainability. Our goal is to support you in boosting your productivity and efficiency by offering tailored solutions for your manufacturing requirements.

Last but not least, our workforce stands behind all our products. The measure of success for their work is the satisfaction of our customers. We know that long-term commercial success can only be achieved through top quality products and services, where all related tasks need to be perfectly executed at all times.

In our new catalogue, discover how we can help revolutionize your processes with our high-quality components. Do you have questions or desire a personal consultation? Our team of experts is here to help. We look forward to accompanying you every step of the way to your perfect automation solution!

Rhein-Nadel Automation GmbH – we handle it.

## Overview

Component	Colour in catalogue
Vibratory Feeders and Bowl Feeders	Red
Linear Feeders	Yellow
FlexCubes (not shown on right)	Green
Belt Feeders (not shown on right)	Light Green
Hopper Systems	Blue
Step Feeders (not shown on right)	Cyan
Controllers (not shown on right)	Orange

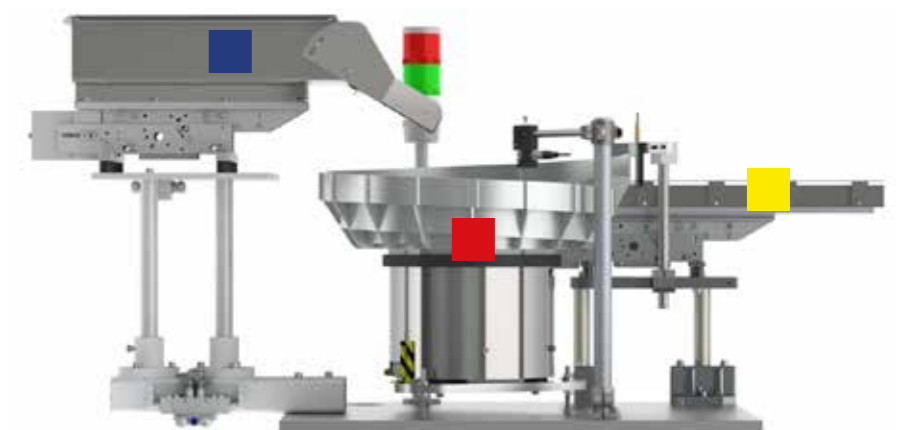

Revision date: March 2025

We reserve the right to make technical changes.

© by RNA Rhein-Nadel Automation GmbH

Notice: RNA represents that the delivery items described in this catalogue will have the agreed characteristics at the time of transfer of risk. These characteristics will be defined exclusively by the concrete, written agreements between RNA and Buyer regarding the properties, features and performance characteristics of the respective delivery item. Illustrations and information provided in catalogues, price lists and other information materials submitted to Buyer by RNA, as well as product-describing information, are legally binding only where they are explicitly identified as binding information. Such information shall in no way be construed as guarantees of a particular characteristic of the delivery item. Such guaranteed characteristics must be expressly agreed in writing. RNA reserves the right to make changes to the contents of this catalogue at any time.

# DigitalMotion – Tuning drives in the Cloud

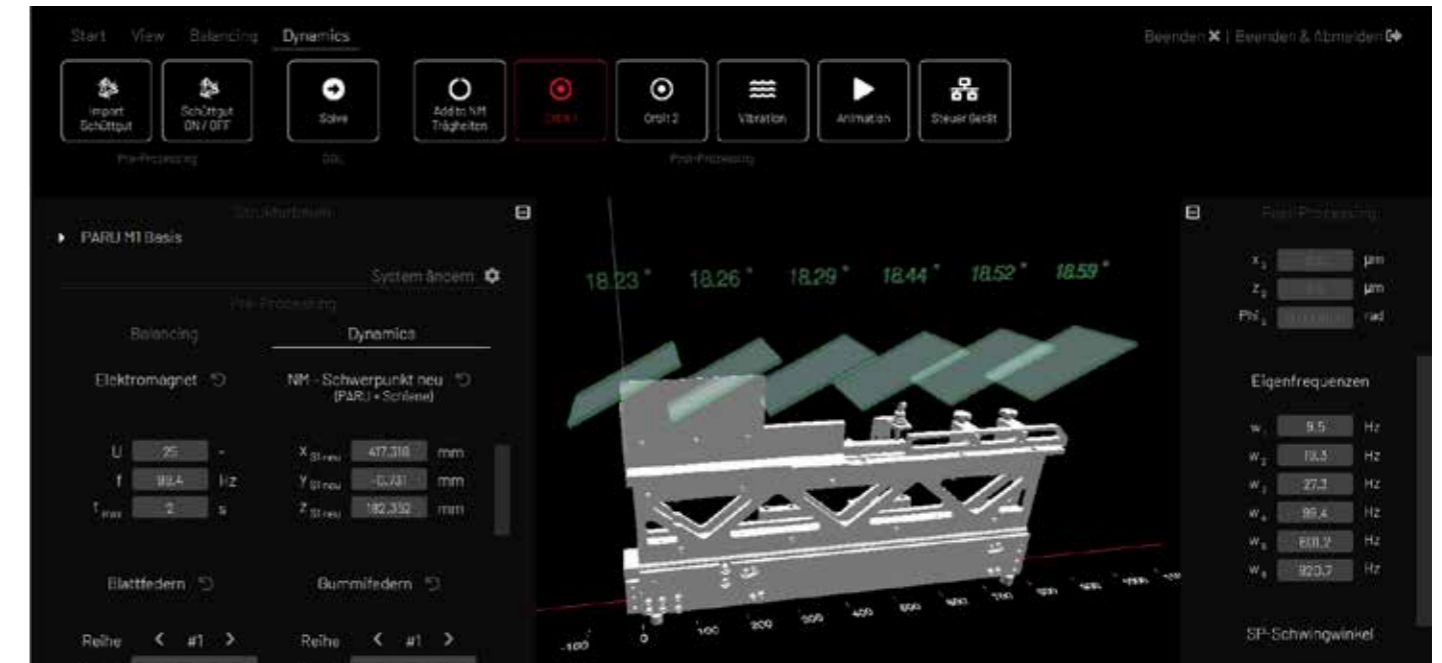
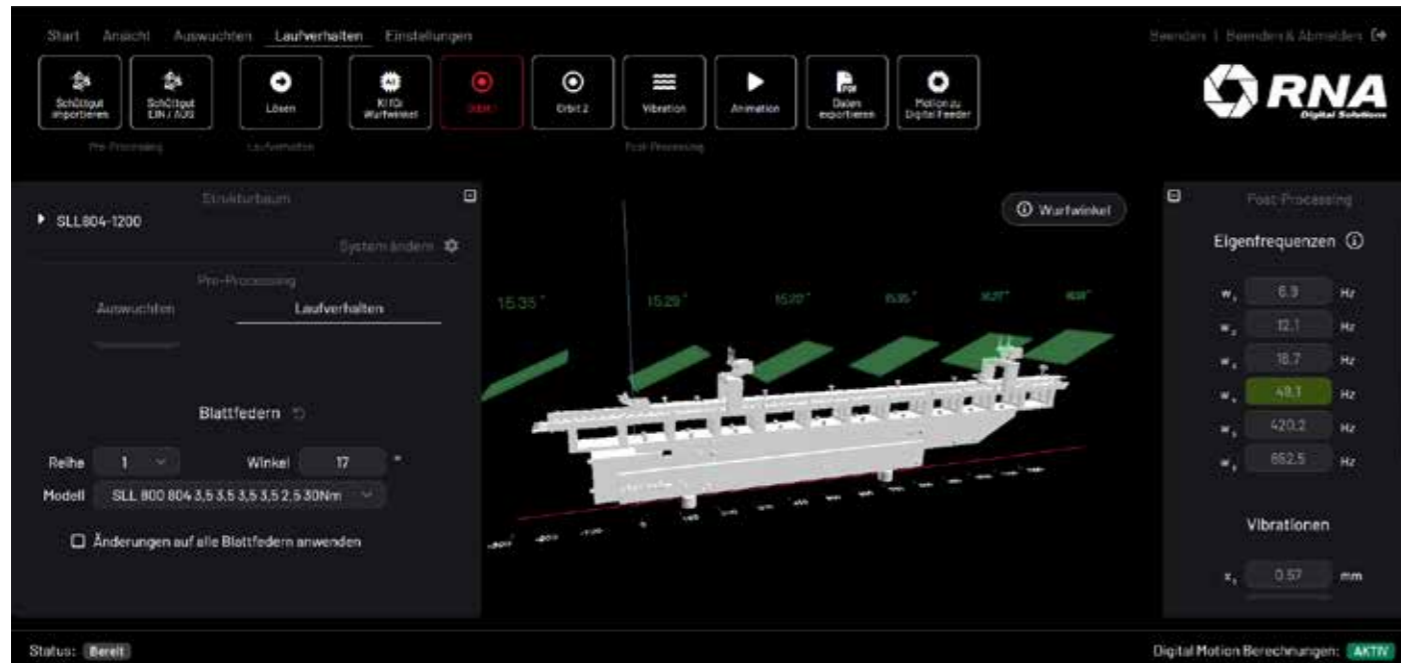

The browser-based DigitalMotion software enables you to tune the feeding behaviour of RNA components with a few clicks. This saves valuable time during initial commissioning of your drives, creates a reproducible set-up with clear documentation, and forms the basis for optimal operation of your feeding system in the long term.

## Simple workflow

DigitalMotion can be seamlessly integrated into your existing processes. All you need is the CAD design data of your feeder rail or bowl. The graphic presentation of the simulation results and integrated interpretation aids make the tuning process child's play. Exporting the results to a \*.pdf file provides you with a documentation that will help you install the drives on your own, or to order pre-configured drives from RNA. This makes DigitalMotion your tool to combat the shortage of skilled personnel in the field of feeding technologies.

## High return-on-Investment

The use of DigitalMotion does not only permit direct savings during commissioning of your drives. Correctly setting up the feeding behaviour is actually the basis for optimal long-term operation of feeding systems. In this manner, you benefit twice over: In your own shops and in the production facilities of your customers.

## Digitized drives from RNA

Due to the positive feedback from our customers, we are constantly updating DigitalMotion with additional RNA components. At present, following products are already incorporated in this software:

- SLL series (SLL 175, SLL 400, SLL 800, SLL 804)
- PARU Mini
- SRC-N series (160, 200, 250, 400)



## Example: calculation of the savings for tuning an SLL 800-800:



Ø number of parameter variations on an SLL (leaf springs: stiffness, inclination...)

Ø duration per adaptation

Hourly rate in shop

Cost savings per drive using simulation

## Numerous access options

DigitalMotion offers various access solutions tailored to your specific needs. Our Credit System is an excellent option for all customers requiring digital validations occasionally only. Under our monthly subscription scheme you will have full access to the simulation feature, with an unlimited number of calculations. Be sure to contact your RNA representative for additional information, personalized solutions or a non-binding test phase.

## RNA's Vibratory Feeders

This section comprises our complete portfolio of vibratory feeders available from stock. In addition to the bowl drives, this includes the feeder bowls, bowl centres, controllers and extended accessories such as stands, base plates, sound enclosures, and sensors. These components are completed through the installation of orienting devices (baffles) to become a functional system.

The present catalogue is intended primarily for customers who will implement these baffles themselves.

Due to their excellent capabilities and the wide range of sizes, RNA drives for vibratory feeding systems are regarded as an industry standard. Our product portfolio in addition includes all other known components of feeding systems, such as linear feeders, step feeders or centrifugal feeders, as well as vibratory platforms and belt feeders.

RNA's vibratory drives are renowned for their very low fault rates. They function smoothly and reliably even in continuous operation.





The use of high-performance magnets enables high, load-independent feed rates and compact dimensions in applications with 50 Hz and 100 Hz vibrating frequency. They are available in the sizes SRC-N 63 through SRC-N 800.

RNA's vibratory drives are regarded as industry standard and are all available from stock. We will also be happy to manufacture vibratory feeders to your special requirements, e.g. with customized spring configuration, increased performance, protective enclosures with special paint finishes or made from stainless steel, customer-specific connectors or EMC power cords (for use with variable frequency controllers).



# 1.) Select the feeder bowl

Use the selection table below to define the bowl geometry (cylindrical, conical, stepped).

Feeder bowl	Bowl geometry & special suitability
	Cylindrical bowls for uniform feeding of the products and for small parts
	Conical bowls for heavy, sharp-edged parts, larger filling quantities, automatic singulation  RG variant: parts for the pharmaceutical and food industries
	Stepped bowls for larger filling quantities and larger parts, see also conical bowls
	Plastic feeder bowls (conical or stepped version) small parts with simple geometries and serial production applications

Bowl shape	Material	Size	Spiral track width (mm)	Bowl height	Feeding direction
C = cylindrical	A = aluminium		X = variable width of spiral track	from mounting surface	r = to right (clockwise) l = to left (anticlockwise)
K = conical	S = steel				
T = stepped	K = plastic				

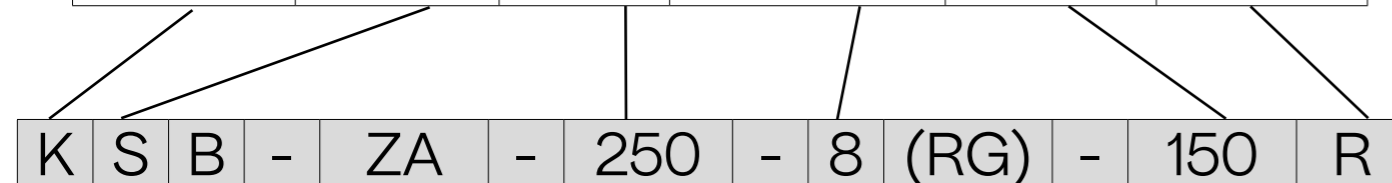

Method of manufacture	Bowl centre/fastening variants	Spiral shape
B = steel sheet construction	N = "nothing" - additional bowl centre required	R = right-angled
D = printed	Z = central attachment with welded or cast bowl centre	G = closed
F = milled	B = welded bowl centre	
G = cast	A = adapter plate	
	2A = additional adapter plate for central fastening	

# 2.) Determine the size:

Depending on the task at hand, selection of the spiral track width (dimension B) and the filling volume will determine the requisite size of the feeder bowl. A matching drive is associated to the feeder bowl. For easy installation of the unit we recommend the use of a baseplate. The permitted product volume and weight in feeder bowls are specified in the descriptions of the individual bowls. The size indication refers to the diameter of the drives (rounded off).

Please be sure to mention the type designation in your inquiries and purchase orders.

Size	250	400	630	800
Cylindrical bowls Stainless steel sheet	ZSB-N 250-30-110 ZSB-ZA 250-30-125	ZSB-N 400-30-100 ZSB-BA 400-30-175 ZSB-Z2A 400-30-190	ZSB-N 630-30-100 ZSB-BA 630-50-195	ZSB-B 800-80-220
Conical bowls Stainless steel sheet	KSB-N 250-20-90 KSB-ZA 250-20-105 KSB-ZA 250-20-150 KSB-ZA 250-8RG-150	KSB-N 400-50-160 KSB-BA 400-50-175 KSB-BA 400-15RG-220 KSB-Z2A 400-50-190 KSB-Z2A 400-15RG-235	KSB-N 630-50-180 KSB-BA 630-50-190 KSB-BA 630-15RG-250	KSB-B 800-80-170
Stepped bowls Cast aluminium	TAG-N 250-20-105 TAG-N 250-32-130 TAG-N 250-32-145 TAG-ZA 250-32-165 TAG-ZA 250(541)-32-180	TAG-N 400-32-175 TAG-N 400-50-190 TAG-N 400-50-215 TAG-ZA 400-50-240	TAG-N 630-50-220 TAG-N 630-65-230 TAG-ZA 630-50-240 TAG-ZA 630-65-250	
Plastic bowls milled	KKF-ZA 250-X-100 TKF-ZA 250-X-100	on request		
Fixed bowl centre	SRF-N 250(PA) SRF-N 250(AL) SRF-N 250(VA)	SRF-N 400(PA) SRF-N 400(AL) SRF-N 400(VA)	SRF-N 630(PA) SRF-N 630(VA)	
Loose bowl centre	SRL-N 250(PA) SRL-N 250(AL)	SRL-N 400(PA) SRL-N 400(AL)	SRL-N 630(AL)	
Adapter plates	AAG-Z 250	AAG-R 400 AAG-R400(544) SA AAG-Z 400 AAG-Z 400(Z) AAG-Z 400(250)SA	AAG-ZB 630 AAG-R 630 AAG-R 630(666)SA	
Drives	SRC-N 250-2 SRC-B 250-2	SRC-N 400-2 SRC-N 400-1 SRHL 400-2 SRHL 400-1	SRC-N 630-1	SRC-N 800-1
Baseplates	SRG-250 USJ-250	SRG-400 USJ-400	SRG-630 USJ-630	
Mounting plates	UP 250	UP 400	UP 630	

# 3.) Define the feeding direction:

- 1) Left-hand version (anticlockwise feeding direction)
- 2) Right-hand version (clockwise feeding direction)



Fig.: Anticlockwise feeding direction



Fig.: Clockwise feeding direction

# Selection matrix for bowl feeders

Drive size 100 - 200

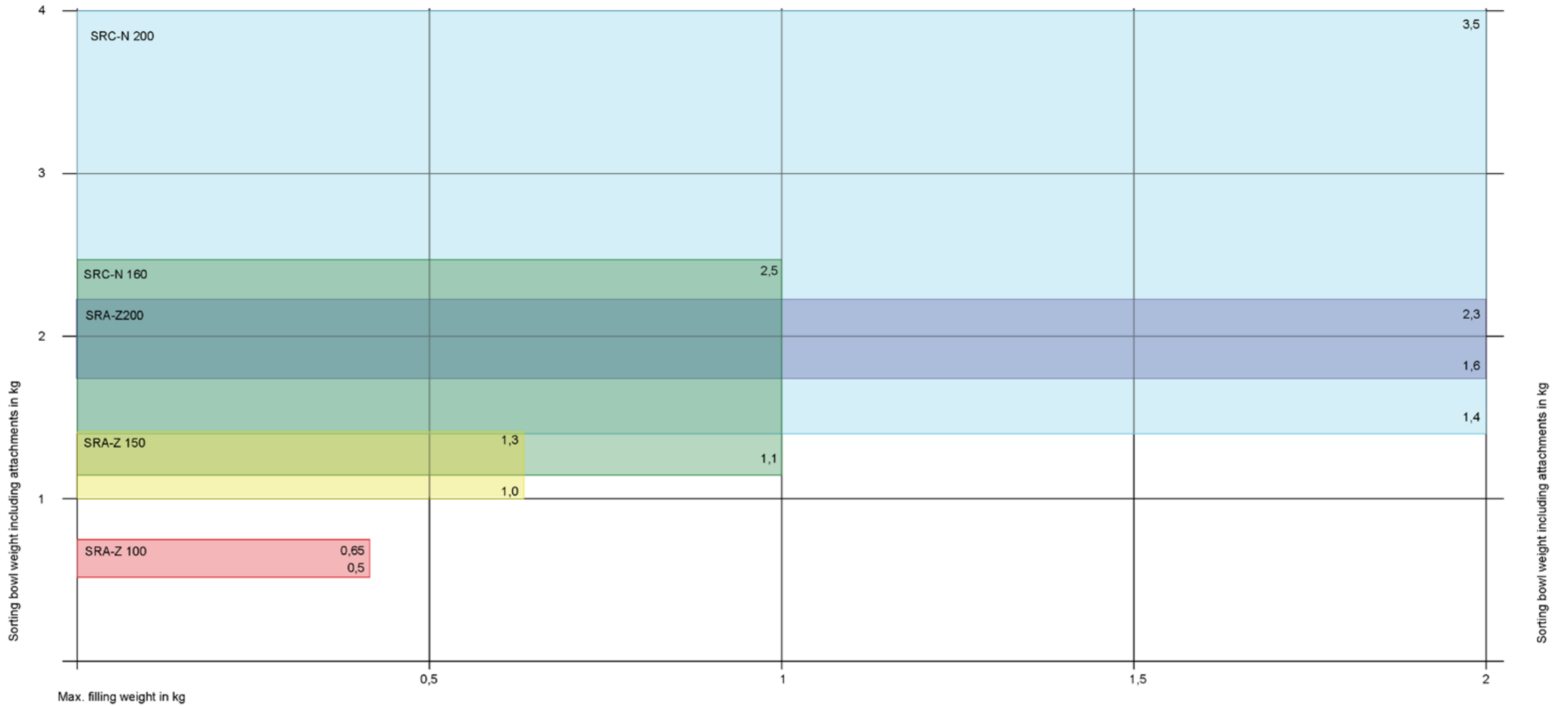

# Selection matrix for bowl feeders

Drive size 250 - 800

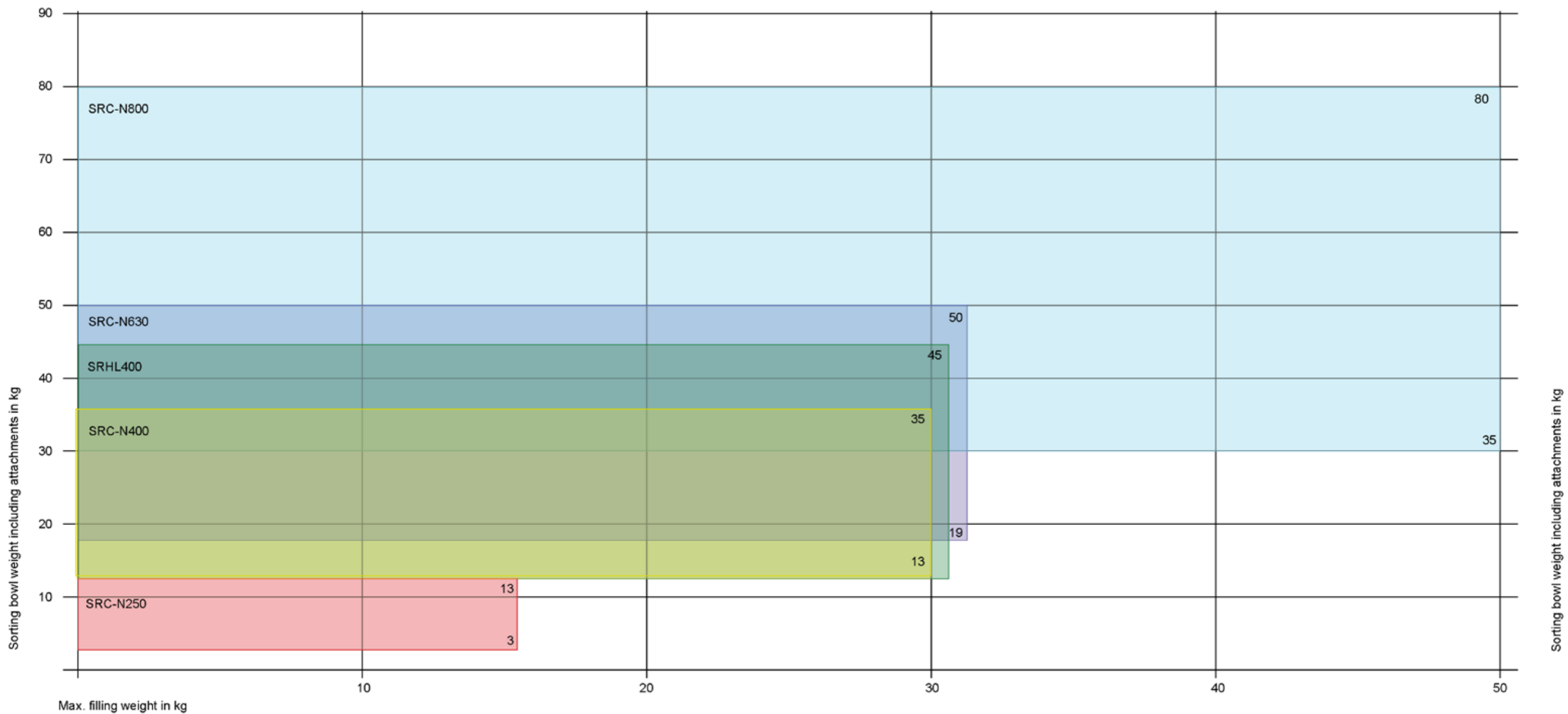

# Bowl drive series SRA-Z



### Infos

- Drives of the SRA-Z series do not require a protective enclosure.
- Customized spring configurations

### Description

SRA-Z bowl drives are our smallest drives. They are appreciated for their low fault rates and compact design. They provide a high degree of reliability and operational safety in continuous operation. The use of high-performance magnets enables high, feed rates independent of loading, and compact dimensions. The vibrating frequency of 100 Hz ensures a very fine part running behaviour in the devices. This is particularly helpful for handling parts with minor discernible orientation characteristics. It also helps implement critical interface transitions.

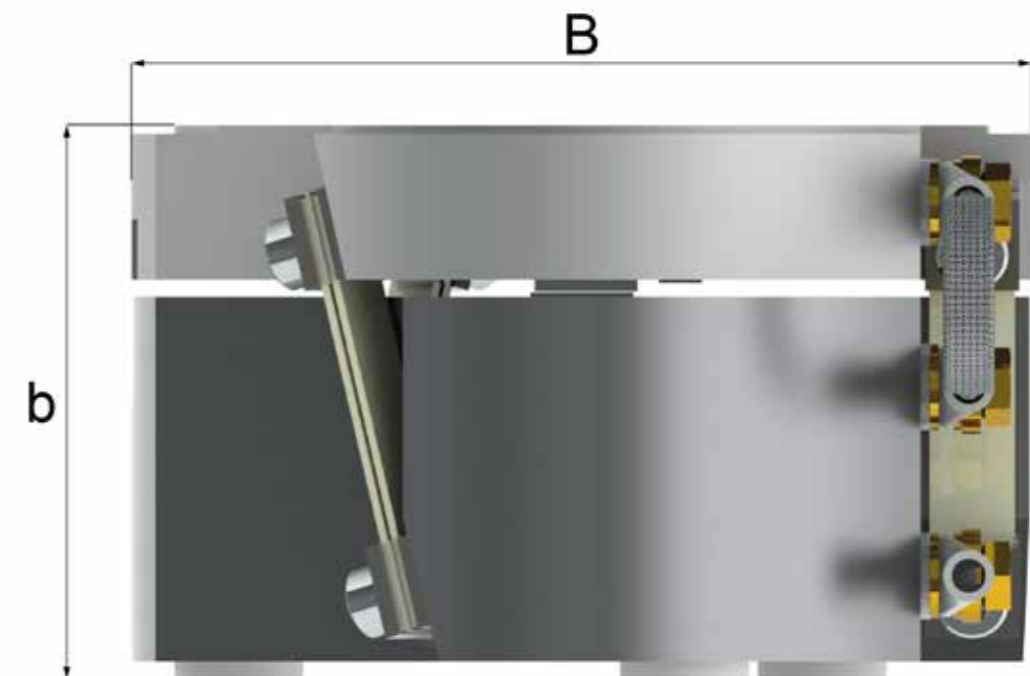

Fig.: SRA-Z 150

Typical application: SRA-Z150 and SRA-Z100 with RNA standard 3D feeder bowl for metal pins



Type	SRA-Z 100-2	SRA-Z 150-2	SRA-Z 200-2
B = outside drive Ø (mm)	105	148	195
Vibration isolator hole circle Ø (mm)	82	120	175
Isolator pitch (degrees°)	120	120	120
Isolator fastening thread (metric)	M4	M4	M6
Central fastening of feeder bowl (metric)	M6	M8	M8
b = height of drive (mm)	64.5	61.5	130
Weight of drive (kg)	2.2	3.6	10.5
Max. weight of feeder bowl [kg]	0.65	1.3	2.3
Max. filling weight (kg)	0.4	0.6	2
Current input (A)	0.12	0.36	1.42
Vibrating frequency (Hz / min-1)	100 / 6000	100 / 6000	100 / 6000
Connecting cable length (m)	1.5	1.5	1.5
Nominal voltage: Magnet voltage / frequency (V/Hz)	200 / 50	200 / 50	200 / 50
Implemented standard(s)	CE	CE	CE

# Bowl drive series SRC-N 160 to 200



### Infos

We will be happy to build drives in the configuration of your choice:

- Customized spring configurations
- Extended or shielded connecting cables
- Protective enclosures in stainless steel or painted the colour of your choice
- Specific connectors
- Available for different voltages and frequencies

### Description

Drives SRC-N 160-2 and SRC-N 200-2 are the smallest drives in our renowned SRC family. A centrally arranged high-performance magnet in combination with three freely configurable leaf spring packs ensures smooth and powerful transmission of vibrations. The drives are fitted with steel leaf springs for safe and reliable operation. These steel springs also ensure constant feed rates even in continuous operation and in the presence of temperature fluctuations. The drives are designed for a vibrating frequency of 100 Hz so that parts with particularly small discernible orientation characteristics can be oriented in the feeder bowl. The feeder bowl is held in place by a central fastening screw. We will be happy to build the drive in accordance with your specifications.

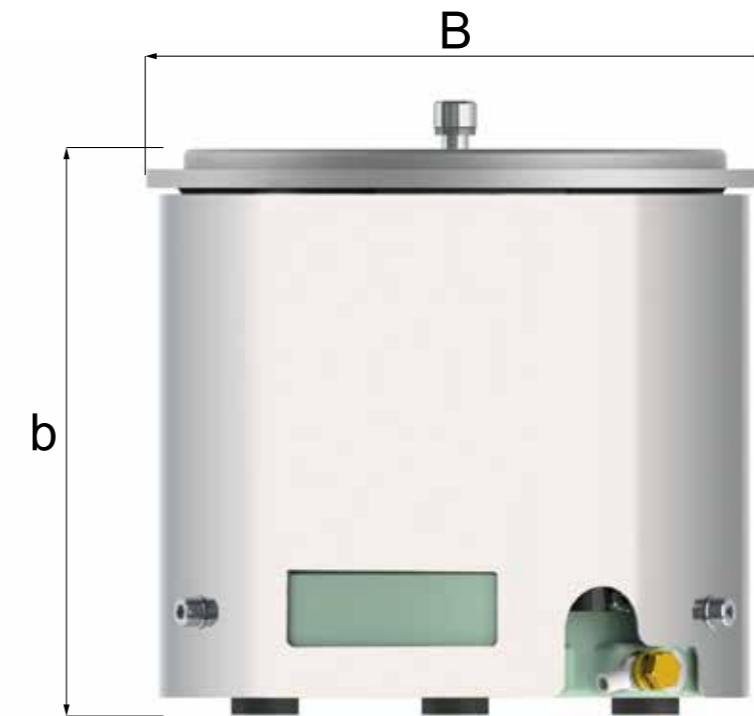

Fig.: SRC-N

Typical application: SRC-N 200 with RNA standard 3D feeder bowl for screws, balls and O-rings



Type	SRC-N 160-2	SRC-N 200-2	SRC-B 200-2
B = outside drive Ø (mm)	157	180	180
Feeder bowl spigot Ø (mm)	150	161	161
Vibration isolator hole circle Ø (mm)	120	130	130
Isolator pitch (degrees°)	120	120	120
Isolator fastening thread (metric)	M4	M4	M6
Central fastening of feeder bowl (metric)	M8	M8	M8
b = height of drive (mm)	132	165	165
Weight of drive (kg)	7	11	11
Max. weight of feeder bowl [kg]	2.5	4	4
Max. filling weight (kg)	1.0	2.0	2.0
Current input (A)	0.6	1.2	1.2
Vibrating frequency (Hz / min-1)	100 / 6000	100 / 6000	100 / 6000
Connecting cable length (m)	1.4	1.4	1.4
Nominal voltage: Magnet voltage / frequency* (V/Hz)	200 / 50	200 / 50	200 / 50
Implemented standard(s)	CE, CSA/UL	CE, CSA/UL	CE, CSA/UL

\*Other voltages and frequencies available: 220V, 200V, 110V, each with 50Hz or 60Hz

# Bowl drive series SRC-N 250 to 630

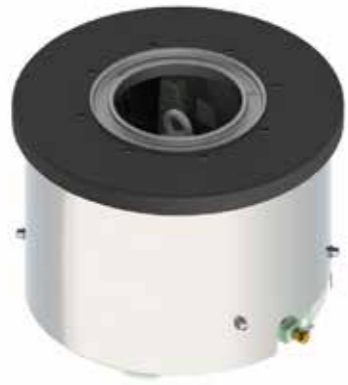

### Infos

We will be happy to build drives in the configuration of your choice:

- Customized spring configurations
- Extended or shielded connecting cables
- Protective enclosures with special paint jobs
- Specific connectors
- Available for different voltages and frequencies

### Description

Bowl drives of the SRC-N 250 to 630 series are among the most used vibratory feeders worldwide. They are powerful tools and distinguish themselves by their high operational safety and reliability in continuous operation. The combination of high-performance magnets with specially made leaf springs provides users with quasi load-independent, high feeding capacities and speeds. Their compact and uncomplicated design makes them easy to tune and work on.

Our drives have IP54 protection rating.

In their standard version, they come with painted (RAL 7035) or stainless steel protective enclosures.

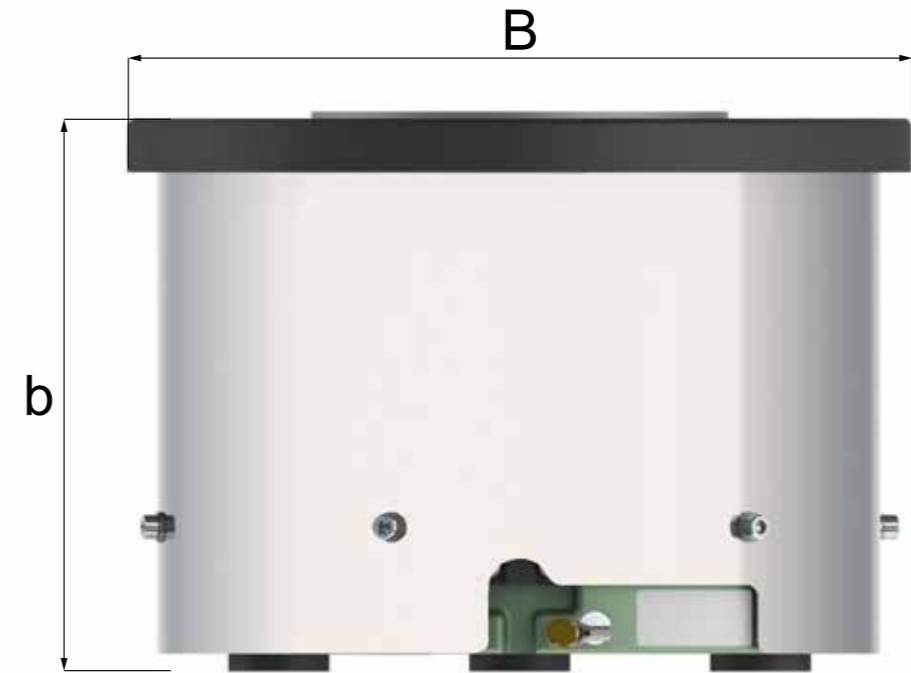

Fig.: SRC-N 250-2

Typical application: SRC-N 250-2L with RNA standard 3D feeder bowl, multi-lane version for plastic parts



Type	SRC-N 250-2	SRC-B 250-2	SRC-N 400-2	SRC-N 400-1	SRC-N 630-1
B = outside drive Ø (mm)	290	290	440	440	660
Feeder bowl spigot Ø (mm)	165	165	300	300	500
Feeder bowl bolt hole circle Ø (mm)	186	186	320	320	525
Vibration isolator hole circle Ø (mm)	220	220	350	350	560
Isolator pitch (degrees°)	120°	120°	120°	120°	120°
Isolator fastening thread (metric)	M8	M8	M10	M10	M10
Central fastening of feeder bowl (metric)	M6 / 45°	M6 / 45°	M6 / 30°	M6 / 30°	M6 / 30°
b = height of drive (mm)	218	218	228	228	227
Weight of drive (kg)	40	40	103	103	168
Max. weight of feeder bowl [kg]	13	13	20	35	50
Max. filling weight (kg)	15	15	30	30	30
Current input (A)	2.6	4,26	4.05	3.75	5
Vibrating frequency (Hz / min-1)	100 / 6000	100 / 6000	100 / 6000	50 / 3000	50 / 3000
Connecting cable length (m)	2.5	2.5	2.5	2.5	2.5
Nominal voltage: Magnet voltage / frequency* (V/Hz)	200 / 50	200 / 50	200 / 50	200 / 50	200 / 50
Implemented standard(s)	CE, CSA/UL	CE, CSA/UL	CE, CSA/UL	CE, CSA/UL	CE, CSA/UL

\*Other voltages and frequencies available: 220V, 200V, 110V, each with 50Hz or 60Hz

# Bowl drive series SRHL

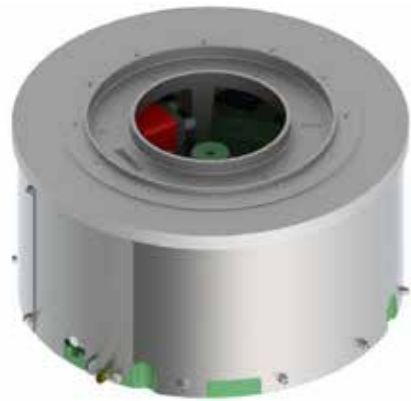

### Infos

We will be happy to build drives in the configuration of your choice:

- Customized spring configurations
- Extended or shielded connecting cables
- Protective enclosures with special paint jobs
- Specific connectors
- Available for different voltages and frequencies

### Description

Bowl drives of the SRHL series are high-performance drives that are used whenever high loads and high feeding rates are required.

The use of two powerful magnets in combination with six freely configurable leaf spring packs provides sufficient forward movement and permits safe operation even with high amplitudes. Depending on the sorting task at hand, you can order the SRHL drives with full-wave or half-wave frequency.

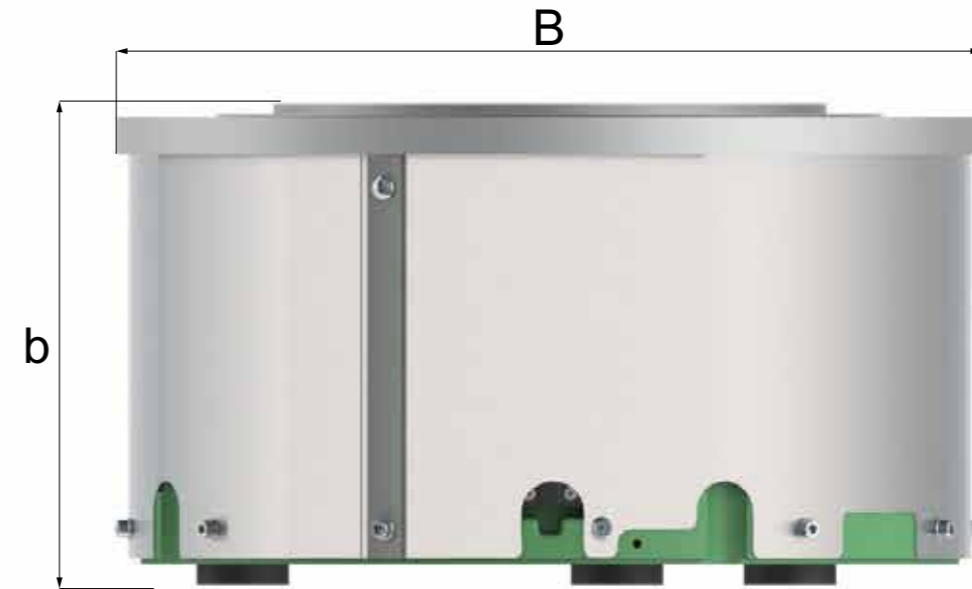

Fig.: SRHL 400-2

Typical application: SRHL 400-2L with standardised, electropolished V2A feeder bowl for O-rings, feeding rate 800 parts/minute



Type	SRHL 400-2	SRHL 400-1
B = outside drive Ø (mm)	470	470
Feeder bowl spigot Ø (mm)	300	300
Feeder bowl bolt hole circle Ø (mm)	320	320
Vibration isolator hole circle Ø (mm)	350	350
Isolator pitch (degrees°)	120°	120°
Isolator fastening thread (metric)	M10	M10
Central fastening of feeder bowl (metric)	M6 / 30°	M6 / 30°
b = height of drive (mm)	255	255
Weight of drive (kg)	140	140
Max. weight of feeder bowl [kg]	45	45
Max. filling weight (kg)	30	30
Current input (A)	5,3	5,7
Vibration frequency (Hz / min-1)	100 / 6000	50 / 3000
Connecting cable length (m)	2.5	2.5
Nominal voltage: Magnet voltage / frequency* (V/Hz)	200 / 50	200 / 50
Implemented standard(s)	CE, CSA/UL	CE, CSA/UL

\*Other voltages and frequencies available: 220V, 200V, 110V, each with 50Hz or 60Hz

# Bowl drive series SRC-N 800

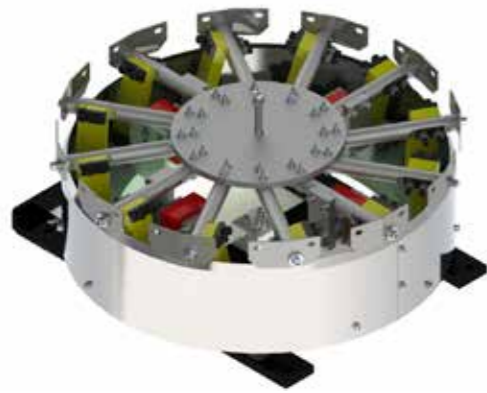

### Infos

We will be happy to build drives in the configuration of your choice:

- Customized spring configurations
- Extended or shielded connecting cables
- Protective enclosures with special paint jobs
- Specific connectors
- Available for different voltages and frequencies

### Description

The SRC-N 800 is the largest bowl drive in RNA's product portfolio. It is designed for particularly large and heavy bowls. With its four high-powered magnets combined with twelve freely configurable leaf spring packs, it offers a feeding capacity that is nearly independent of loading, and allows users to realize high amplitudes with excellent process reliability. Feeder bowls are radially fastened from outside at 12 fastening points. Our drives have IP54 protection rating. In their standard version, they come with painted (RAL 7035) or stainless steel protective enclosures.

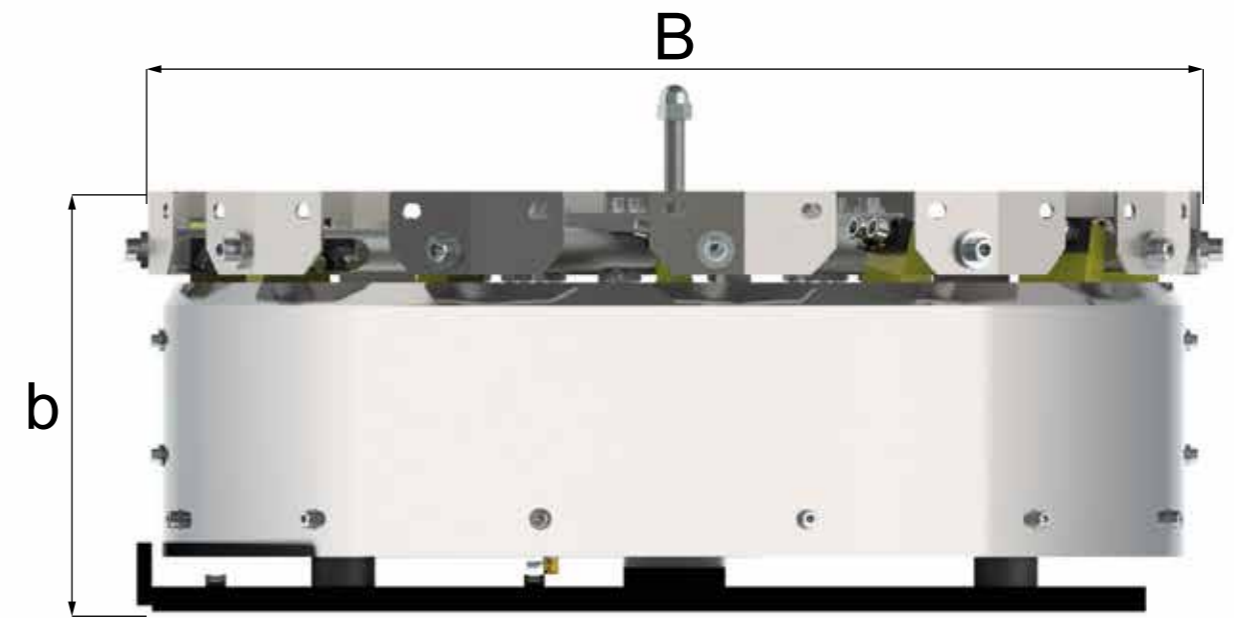

Fig.: SRC-N 800-1

Typical application: KSB-B 800 in combination with SRC-N 800 for properly oriented feeding of rectangular parts



Type	SRC-N 800-1
B = outside drive Ø (mm)	850
Feeder bowl spigot Ø (mm)	820
Feeder bowl bolt hole circle Ø (mm)	M10 / 15°
Vibration isolator hole circle Ø (mm)	M12 / 30°
Isolator pitch (degrees°)	735
Isolator fastening thread (metric)	90°
Central fastening of feeder bowl (metric)	M10
b = height of drive (mm)	315
Weight of drive (kg)	253
Max. weight of feeder bowl [kg]	80
Max. filling weight (kg)	50
Current input (A)	8.5
Vibrating frequency (Hz / min-1)	50 / 3000
Connecting cable length (m)	2.5
Nominal voltage: Magnet voltage / frequency* (V/Hz)	200 / 50
Implemented standard(s)	CE, CSA/UL

\*Other voltages and frequencies available: 220V, 200V, 110V, each with 50Hz or 60Hz

# Feeder bowl series TAG-N



### Infos

We will be happy to manufacture customer-specific feeder bowls:

- Reproducible design
- Low noise level
- Stable mounting points for orienting tooling
- Special paint jobs
- Different coatings
- Choice of bowl centres

### Description

The stepped feeder bowl TAG-N is made from aluminium. It offers a very high stiffness, which ensures uniform feeding of the parts. Feeder bowls from this series offer a very large filling volume, but without parts getting stuck under the spiral track.

Feeder bowls of the TAG-N series can be combined with different bowl centres. The bowl is radially fastened from top directly to the vibrating unit of the SRC-N bowl drive.

In combination with a bowl coating, the unit generates very little noise during operation.

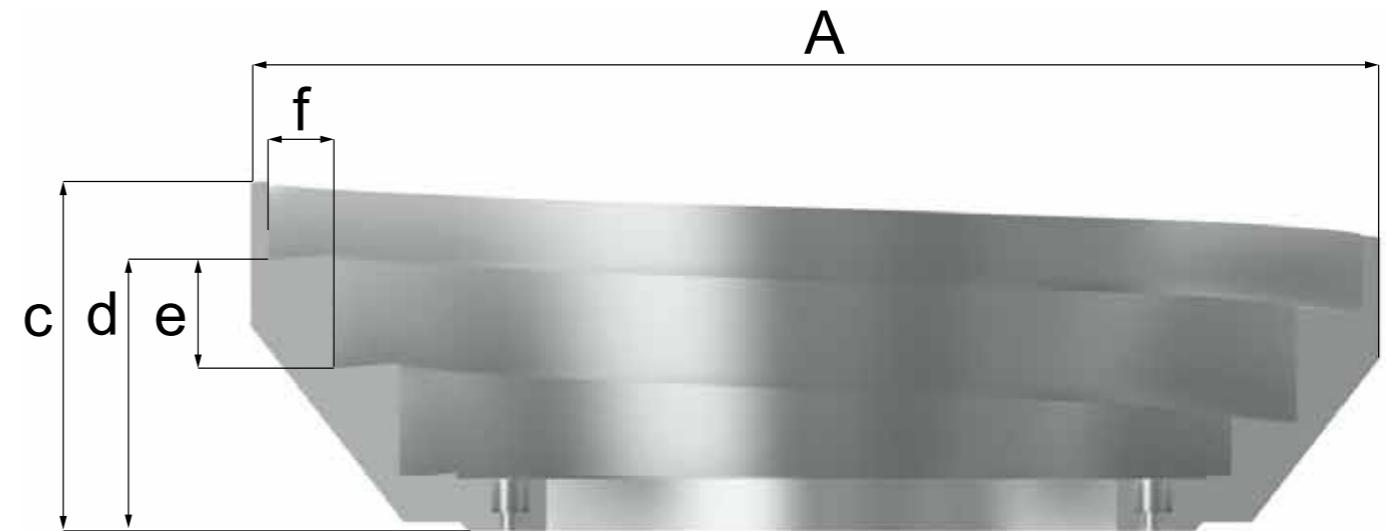

Typical application: SRC-N 200 with TAG-Z 200



Type	TAG-N 250-20-105	TAG-N 250-32-130	TAG-N 250-32-145	TAG-N 400-32-165	TAG-N 400-50-190	TAG-N 400-50-215	TAG-N 630-50-230	TAG-N 630-65-230
A = outside bowl Ø (mm)	330	400	400	545	645	645	830	830
c = bowl height (mm)	102	122	140	165	190	215	222	230
d = discharge height of feeder bowl (mm)	77	90	107	124	138	162	157	157
e = spiral track pitch (mm)	34	42	42+15***	50+15***	68	68+23***	76	95
F = spiral track width (mm)	20	32	32	32	50	50	50	65
Weight of feeder bowl (kg)	1.65	2.9	3.4	5	9	11.7	18	18
Max. weight of feeder bowl incl. add-ons (kg)	13	13	13	20* / 35**	20* / 35**	20* / 35**	50	50
Max. filling quantity (kg / l)	15 / 2	15 / 2	15 / 2	30 / 0	30 / 10	30 / 10	30 / 20	30 / 20

\*Max. bowl weight for SRC-N 400-2 drive

\*\*Max. bowl weight for SRC-N 400-1 drive

\*\*\*Additional spiral track gradient over at the last 180°

# Feeder bowl series TAG-Z



### Infos

We will be happy to manufacture customer-specific feeder bowls:

- Reproducible design
- Low noise level
- Cast-in bowl centre
- Stable mounting points for orienting tooling
- Special paint jobs
- Different coatings

### Description

Stepped feeder bowls of the TAG-Z series are made from aluminium. Their design offers very high strength, ensuring even and quiet feeding of the parts. Thanks to their design they also have a large filling volume, without the parts getting stuck under the spiral track.

TAG-Z stepped feeder bowls are made with cast-in bowl centres. The bowl centre is designed so that the feeder bowl is connected to the bowl drive by a central fastening screw.

In combination with a bowl coating, the unit generates very little noise during operation.

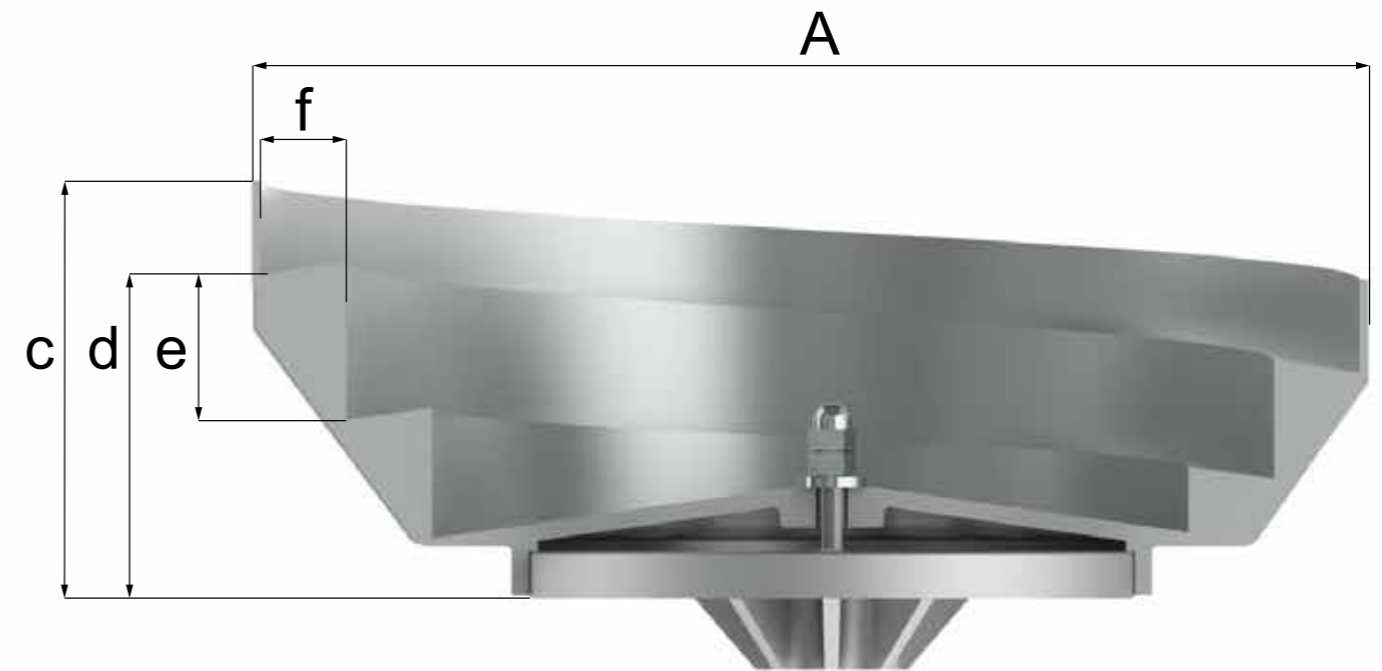

Typical application: SRC-N 400-1 with TAG-ZA 400 and bolted-on orienting device



Type	TAG-Z 200-10-80	TAG-Z 200(324)-20-105	TAG-ZA 250-32-165	TAG-ZA 250(541)-32-180	TAG-ZA 400-50-240	TAG-ZAB 630-50-240	TAG-ZAB 630-65-240
A = outside bowl Ø (mm)	228	330	400	545	650	830	830
c = bowl height (mm)	81	95	160	177	241	242	250
d = discharge height of feeder bowl (mm)	66	71	126	135	188	197	197
e = spiral track pitch (mm)	20	32	42+15***	50+15***	68+23***	76	95
F = spiral track width (mm)	10	20	32	32	50	50	65
Weight of feeder bowl (kg)	0.8	2.6	6.9	8.2	14.7	27	27
Max. weight of feeder bowl incl. add-ons (kg)	3.5	3.5	13	13	20* / 35**	50	50
Max. filling quantity (kg / l)	2 / 0.5	2 / 1.0	15 / 2	15 / 7	30 / 10	30 / 20	30 / 20

\*Max. bowl weight for SRC-N 400-2 drive

\*\*Max. bowl weight for SRC-N 400-1 drive

\*\*\*Additional spiral track gradient over at the last 180°

# Feeder bowl series KSB-N

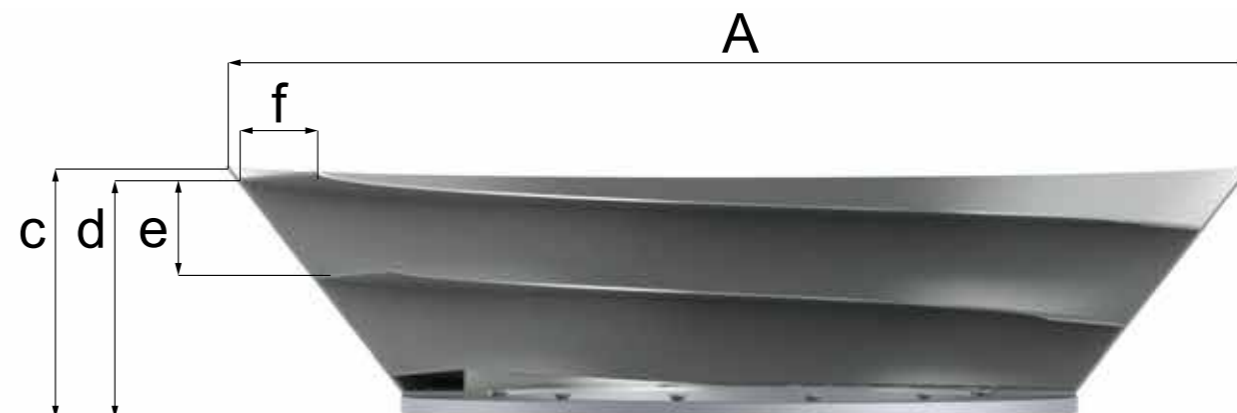

### Infos

We will be happy to manufacture customer-specific feeder bowls:

- Special paint jobs
- Different coatings
- Standard and specially designed bowl centres

### Description

KSB-N series feeder bowls have a conical shape and are made from stainless steel (1.4301). The spiral track with transition from the bowl centre is already welded into the bowl.

Due to the conical shape in feeding direction, the parts will already be spaced out as they advance. For optimal transmission of the vibrations, an aluminium ring is glued to the bowl centre. The bowl is fixed radially from top directly to the vibrating unit of the drive.

As with all N-series bowls, various bowl centres can be installed.

Typical application: SRC-N 250-2 with KSB-N 250 and closed spiral track for feeding of caps



Type	KSB-N 250-20-90	KSB-N 400-50-160	KSB-N 630-50-180
A = outside bowl Ø (mm)	403	670	898
c = bowl height (mm)	89	161	180
d = discharge height of feeder bowl (mm)	77	153	172
e = spiral track pitch (mm)	32	68	70
F = spiral track width (mm)	20	50	50
Weight of feeder bowl (kg)	3.85	12.9	19
Max. weight of feeder bowl incl. add-ons (kg)	13	20* / 35**	50
Max. filling quantity (kg / l)	15 / 2	30 / 10	30 / 20

\*Max. bowl weight for SRC-N 400-2 drive  
 \*\*Max. bowl weight for SRC-N 400-1 drive

# Feeder bowl series KSB-Z and KSB-B



### Infos

We will be happy to manufacture customer-specific feeder bowls:

- Special paint jobs
- Different coatings
- Standard and specially designed bowl centres

### Description

KSB-Z and KSB-B series feeder bowls have a conical shape and are made from stainless steel (1.4301). The spiral track with transition from the bowl centre is already welded into the bowl. Due to the conical shape in feeding direction, the parts will already be spaced out as they advance.

These feeder bowls come with a pre-installed welded bowl centre. The feeder bowls can be mounted on the bowl drive either in central (KSB-Z) or in radial manner from the outside (-BA) in combination with an adapter plate.

We have taken special care to provide for optimal transmission of the vibrations.

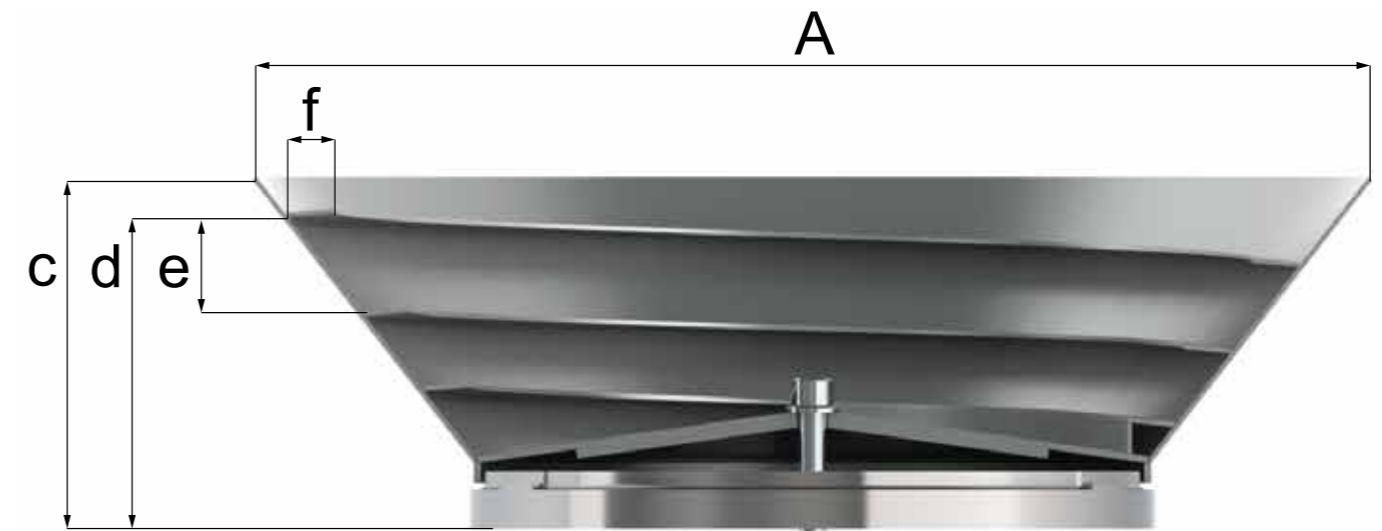

Fig.: KSB-Z

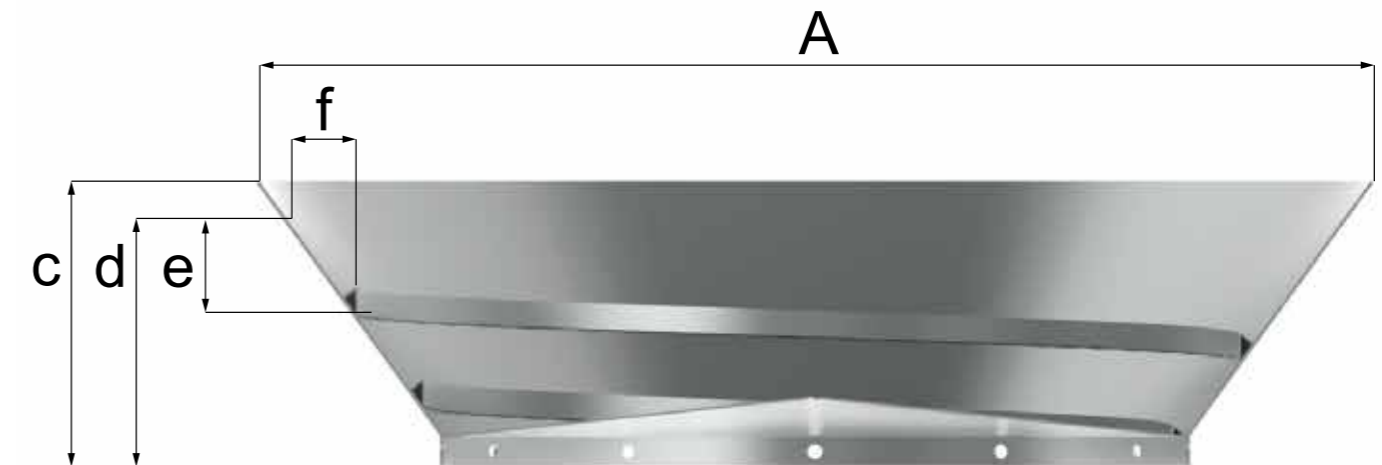

Fig.: KSB-B

Typical application: SRC-N 250 with KSB-ZA 250 feeder bowl of grade 1.4301 material



Type	KSB-Z 200- 5RG-60	KSB-Z 200-18- 55	KSB-ZA 250-20- 105	KSB-ZA 250-20- 150	KSB-ZA 250-8RG- 150	KSB- Z2A 400-50- 190	KSB-BA 400-50- 175	KSB-BA 400- 15RG- 220	KSB-BA 630-50- 190	KSB-BA 630- 15RG- 250	KSB-B 800-80- 170
A = outside bowl Ø (mm)	277	265	415	476	478	670	670	745	898	980	1200
c = bowl height (mm)	58	55	113	151	151	189	173	220	192	250	168
d = discharge height of feeder bowl (mm)	50	47	110	136	138	180	164	169	167	149	148
e = spiral track pitch (mm)	28	25	32	32	40	68	68	71	70	81	64
F = spiral track width (mm)	5	18	20	20	8	50	50	15	50	15	80
Weight of feeder bowl (kg)	1.7	1.46	8.2	9.2	10.8	19.4	13.6	16	21.5	27	35
Max. weight of feeder bowl incl. add-ons (kg)	3.5	3.5	13	13	13	20* / 35**	20* / 35**	20* / 35**	50	50	80
Max. filling quantity (kg / l)	2 / 0.5	2 / 0.5	15 / 2	15 / 2	15 / 2	30 / 10	30 / 10	30 / 10	30 / 20	30 / 20	50 / 30

\*Max. bowl weight for SRC-N 400-2 drive  
 \*\*Max. bowl weight for SRC-N 400-1 drive

# Feeder bowl series ZSB-N



### Infos

We will be happy to manufacture customer-specific feeder bowls:

- Special paint jobs
- Different coatings
- Standard and specially designed bowl centres

### Description

The ZSB-N series feeder bowls have a cylindrical shape and are made from stainless steel (1.4301). The spiral track with transition from the bowl centre is already welded into the bowl. Bowls of this design take up very little space and offer a very even part feeding behaviour. Due to the vertical outer walls, add-on components and braces can be welded on very easily. For optimal transmission of the vibrations, an aluminium ring is glued to the bowl centre. The bowl is fixed radially from top directly to the vibrating unit of the drive.

As with all bowls of the N series, different bowl centres can be installed.

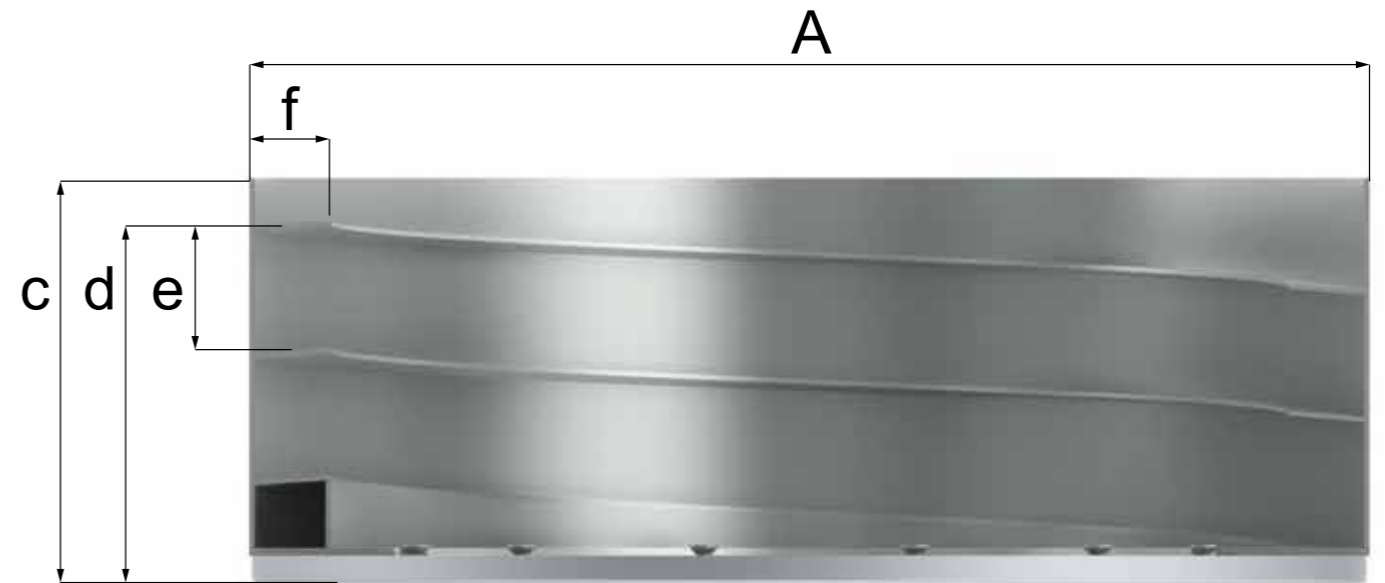

Typical application: SRC-N 250-2 with ZSB-Z 250 for feeding of cases



Type	ZSB-N 250-30-110	ZSB-N 400-30-160	ZSB-N 630-50-180
A = outside bowl Ø (mm)	288	440	670
c = bowl height (mm)	110	160	180
d = discharge height of feeder bowl (mm)	100	140	156
e = spiral track pitch (mm)	35	50	70
F = spiral track width (mm)	30	30	50
Weight of feeder bowl (kg)	4.2	8.4	16.2
Max. weight of feeder bowl incl. add-ons (kg)	13	20* / 35**	50
Max. filling quantity (kg / l)	15 / 1.6	30 / 7	30 / 20

\*Max. bowl weight for SRC-N 400-2 drive  
 \*\*Max. bowl weight for SRC-N 400-1 drive

# Feeder bowl series ZSB-Z and ZSB-B



### Infos

We will be happy to manufacture customer-specific feeder bowls:

- Special paint jobs
- Different coatings
- Standard and specially designed bowl centres

### Description

The KSB-Z and KSB-B series feeder bowls have a cylindrical shape and are made from stainless steel (1.4301). The spiral track with transition from the bowl centre is already welded into the bowl.

Bowls of this design take up very little space and offer a very even part feeding behaviour. Due to the vertical outer walls, add-on components and braces can be welded on very easily. We have taken special care to provide for optimal transmission of the vibrations.

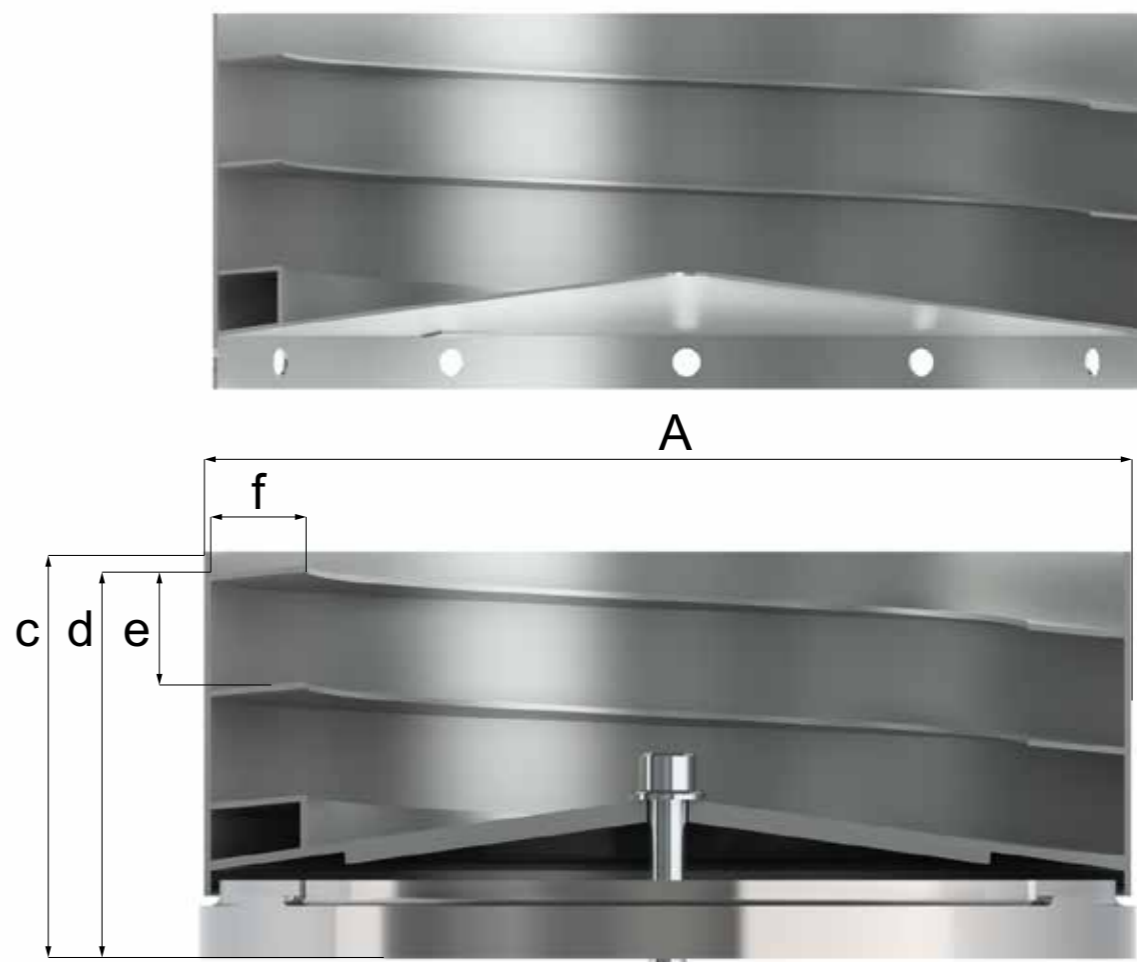

Typical application: SRHL 400-1 with ZSB-BA 400 for multi-lane feeding of plastic parts



Type	ZSB-Z 160-12-70	ZSB-Z 200-12-80	ZSB-ZA 250-30-125	ZSB-BA 400-30-175	ZSB-BA 630-50-195	ZSB-B 800-80-220
A = outside bowl Ø (mm)	168	181	288	440	670	820
c = bowl height (mm)	70	80	127	175	195	220
d = discharge height of feeder bowl (mm)	64	65	120	155	167	195
e = spiral track pitch (mm)	22	22	33***	50	70	70
F = spiral track width (mm)	12	12	30	30	50	80
Weight of feeder bowl (kg)	1.1	1.35	6.4	10.6	18.7	36.8
Max. weight of feeder bowl incl. add-ons (kg)	2.5	3.5	13	20* / 35**	50	80
Max. filling quantity (kg / l)	1 / 0.3	2 / 0.5	15 / 2	30 / 10	30 / 20	50 / 20

\*Max. bowl weight for SRC-N 400-2 drive  
 \*\*Max. bowl weight for SRC-N 400-1 drive

# Printed feeder bowl series KKD-Z



### Infos

- for SRA-Z drives
- specially conceived for very small parts
- Due to the dimensional accuracy of these bowls it is possible to design orienting tools subsequently and fasten them via the existing threaded holes.

### Description

The conical KKD-Z feeder bowl is printed from plastic material and is extremely resistant to wear. The bowl is fixed in place so that the vibrations from the drive unit are transmitted to the bowl and the parts to be fed.

The bowls of this type are designed for reproducibility. Ex-factory, they already comprise a section for the sorting and returning of improperly oriented parts.

The additional sorting and discharge section can be fastened via the existing threaded holes.

These bowls need no coating.

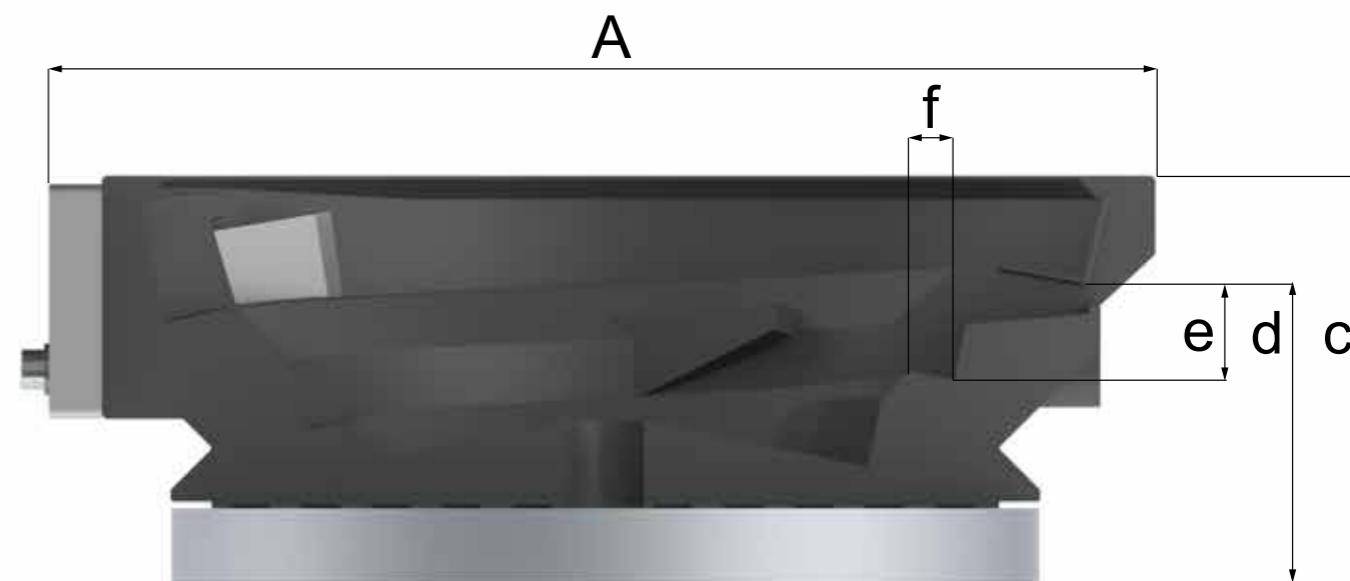

Typical application: SRC-Z 150 with KKD-Z 150 for feeding of washers



Type	KKD-Z 100	KKD-Z 150	KKD-Z 200
A = outside bowl Ø (mm)	135	180	205
c = bowl height (mm)	55	70	85
d = discharge height of feeder bowl (mm)	43	52	62
e = spiral track pitch (mm)	13	17	20
F = spiral track width (mm)	5	7	7.5
Weight of feeder bowl (kg)	0.44	1.0	1.6
Max. weight of feeder bowl incl. add-ons (kg)	0.65	1.3	2.3
Max. filling quantity (kg / l)	0.4 / 0.05	0.6 / 0.2	2 / 0.3

# Milled feeder bowl series KKF-Z and TKF-Z



### Infos

- The different spiral track widths are made to customer's requests. Other spiral track shapes and multiple tracks can also be realized.
- In their standard version, the bowls are made from black PA 6-G.
- Alternative materials are also available
- Type:
  - KKF = conical shape
  - TKF = stepped type
- Please specify "right" (R) or 'left' (L) feeding direction when ordering the bowl

### Description

Milled plastic feeder bowls offer excellent sliding and feeding properties by avoiding the unfavourable 'steel on steel' material combination. The bowl blanks shown here are milled and can be adapted to different spiral track widths. The plastic material causes less abrasion on the bulk products and reduces noise emissions.

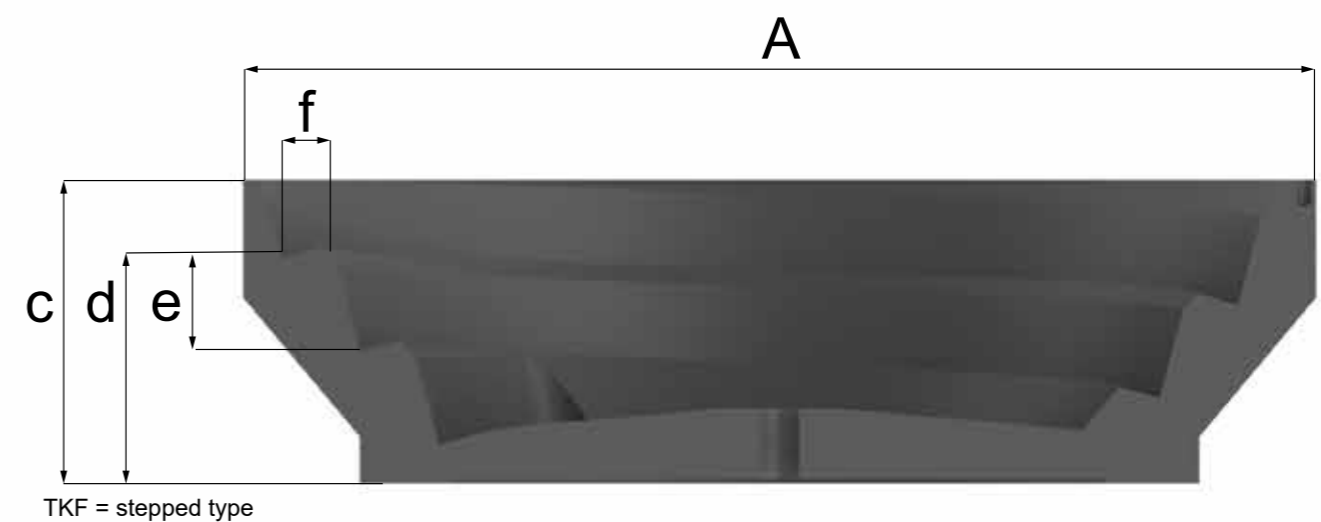
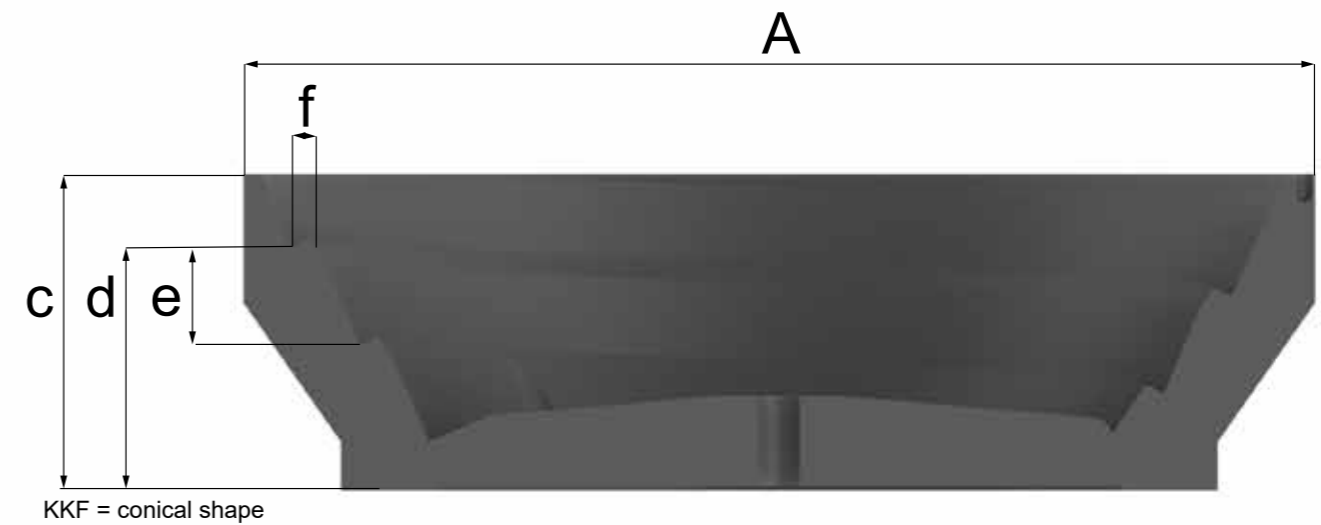

Typical application: SRC-Z 200 with KKF-Z 200 for feeding of thin plates

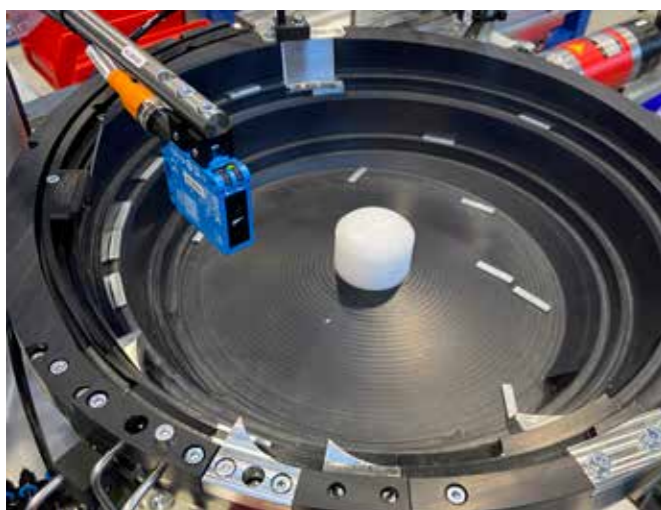

Type	KKF-Z 100-X-40	TKF-Z 100-X-40	KKF-Z 160-X-65	TKF-Z 160-X-65	KKF-Z 200-X-65	TKF-Z 200-X-65	KKF-Z 250-X-100	TKF-Z 250-X-100
A = outside bowl Ø (mm)	120	120	220	230	220	230	400	400
c = bowl height (mm)	40	40	65	65	65	65	100	100
d = discharge height of feeder bowl (mm)	32 - 33	32 - 33	50 - 51	48 - 50	50 - 51	48 - 50	83 - 85	87 - 88
e = spiral track pitch (mm)	12	12	20	20	20	20	36	36
F = spiral track width (mm)	1 - 4	1 - 5	1 - 4	1 - 9	1 - 4	1 - 9	1 - 7	1 - 10
Weight of feeder bowl (kg)	0.208	0.204	0.805	0.87	1.03	1.1	3.15	4.7
Max. weight of feeder bowl incl. add-ons (kg)	0.65	0.65	2.5	2.5	4	4	13	13
Max. filling quantity (kg / l)	0.4 / 0.2	0.4 / 0.2	1 / 1.2	1 / 1.2	2 / 1.2	2 / 1.2	15 / 6	15 / 5
suitable for drive	SRA-Z 100	SRA-Z 100	SRC-N 160	SRC-N 160	SRC-N 200	SRC-N 200	SRC-N 250	SRC-N 250

\* Measured from the vertical  
 \*\* Varies acc.to spiral track width  
 \*\*\* approximate value May vary depending on the material and task at hand

## Accessories for TAG-N, ZSB-N, KSB-N feeder bowls

### Loose centre bowls (non-vibrating)

Loose centre bowls (SRL) for following requirements:

1. Load relief of vibrating system
2. Gentle part handling
3. Noise reduction

Please observe:

Parts presenting unfavourable geometries may get stuck in the gap between bowl centre and bowl. Also, residual parts will remain in the bowl when it is run empty. For heavy parts, we recommend loose bowl centres made from aluminium (SRL AL).

Size	SRL-N 250	SRL-N 400	SRL-N 630
Material	PA, AL	PA, AL	AL



### Fixed bowl centres (vibrating)

Fixed bowl centres (SRF) offer following advantages:

1. Parts won't get stuck in gaps
2. Bowl centre won't jam due to soiling or swarf
3. Feeder bowl can be run completely empty

Size	SRF-N 250	SRF-N 400	SRF-N 630
Material	PA, AL, VA	PA, AL, VA	AL, VA



### Loose bowl centres (non-vibrating)

N-type bowls require the installation of a separate bowl centre.

Available materials:

- PA = plastic
- AL = aluminium
- VA = stainless steel

#### Infos

##### Selection of material:

- **V2A bowl centres (fixed bowl centres only)**  
The perfect choice when there is abrasive wear caused by the parts, e.g. if the bowl is filled from an upstream hopper.
- **Plastic or aluminium bowl centres (PA or AL)**  
Here, the selection of the material depends on the weight and form of the parts handled.
- **Aluminium bowl centres must always be coated, and V2A bowl centres are usually coated as well.**

## Accessories for vibrating feeders/bowls

### Fill level control

Our fill level control devices are known for their compact, rugged design. What's more, they can be connected directly to relays, controllers etc. Also, parts cannot be stuck between the pendulum and the spiral track.

Fill level control devices are used for automatic volumetric control of bulk parts in vibrating feeders, hoppers etc.



Type	EPF24-12	WT12	KI5307
Connection diameter	Ø 12 mm	Ø 12 mm	Ø 14 mm
Operating voltage	10 - 30 VDC	10 - 30 VDC	10-30 VDC
Protection rating	IP67	IP67	IP67
Total cable length beginning at sensor	1,500 mm	1,500 mm	1,500 mm
Fill level control device	Ball or pendulum	Photoelectric sensor	Capacitive sensor
Pendulum swinging range	0° - 45°		

#### Infos

- **In the standard version, a level control device with sensor (24 VDC) and holder (guide tube Ø 12 mm or Ø14 mm) is supplied.**
- **As an accessory, we offer a stand (column height approx. 600 mm) for mounting on a machine table. Additionally, the sensors can be upgraded with a 5-pin connector for connection to an RNA sensor signal amplifier (ESK2000, ESK2001, ESR 2000 and ESR2500).**

# Accessories for vibratory feeders/bowls

## Sound enclosures

In addition to reducing noise levels, sound enclosures also offer protection from dust and dirt.



Type	HK-S 250	HK-S 400	HK-S 630
Total diameter	550	880	1100
Overall height	435	525	565
Height of top section*	230	310	350

\* Dimensions are variable

### Infos

#### Type HK-S sound enclosures:

- Fit vibratory feeders from size SRC- N 250 through SRC-N 630 with type SRG baseplate
- Sheet steel enclosure with acoustic liner glued to the inside
- Exterior painted RAL 7035, structure painted light grey, special paint jobs available on request
- Inset lid (Makrolon)
- For sizes 400 and higher, split lid and hinged lid as special versions

# Accessories for bowl drive series SRC

## SRG baseplates

The baseplate permits easy top-mounting on the machine table. SRG-N baseplates have integrated mounting brackets for controllers. This baseplate is necessary if a cross slide or longitudinal slide is to be used.



Type	SRG-N 160/200	SRL-N 250	SRL-N 400	SRL-N 630
Plat diameter	218	332	485	720
Adapter hole pitch	4 x 140	4 x 220	4 x 325	4 x 488
Adaptability of the plate from below via threads or from top via countersunk holes.	M8 / Km6	M10 / Km8	M10 / Km8	M10 / Km8
Installation height	23	32	32	35

## USJ baseplates

The USJ baseplate serves to mount and align the bowl feeder on the machine table.

The plates are fastened with tension bolts and thrust bolts.



Type	USJ 160/200	USJ 250	USJ 400	USJ 630
Outside diameter	222	360	505	709
Tension bolt hole pitch	3 x 175	3 x 287.5	3 x 434.7	3 x 604.5
Thrust bolt	M6	M8	M8	M8
Plate thickness	15	15	15	15

## Accessories: Substructures/mounting plates/threaded columns

Substructures with threaded columns from RNA offer a very wide adjusting range. Due to the trapezoidal thread used, they permit very fine height adjustment. The large cast feet are prepared for easy anchoring to the floor.

In combination with our threaded columns, the following maximum substructure heights (bottom of foot to top of column) can be achieved: 790 mm/990 mm and 1190 mm. The adjusting range of the columns is 255 mm.



Stand type	UG 400	UG 630
Size	400	630
Foot height	450	450
Foot diameter	340	560

Stand type	UG 400-535	UG 400-735	UG 400-935	UG 630-535	UG 630-735	UG 630-935
A	400	400	400	630	630	630
B <sub>min</sub>	535	735	935	535	735	935
B <sub>max</sub>	790	990	1190	790	990	1190
C	340	340	340	560	560	560

Type UP mounting plate	UP-120	UP-250	UP-400	UP-630
A	120	250	380	550
B	20	21	21	21
C	100	220	325	488

Type UL mounting plate	UL-250	UL-400	UL-630
A	250	380	550
B	44	44	44
C	220	325	488
Total traversing distance X	54	83.5	82

Type UK mounting plate	UK-250	UK-400	UK-630
A	250	380	550
B	64	64	64
C	220	325	488
Total traversing distance X	83.5	83	83.5
Total traversing distance Y	70	83	82



## Accessories: Coatings for feeder bowls

Coatings improve the feeder bowls' resistance to wear. Their use results in gentle part handling and reduced operating noise.

The coating material depends on the application and parts to be handled.

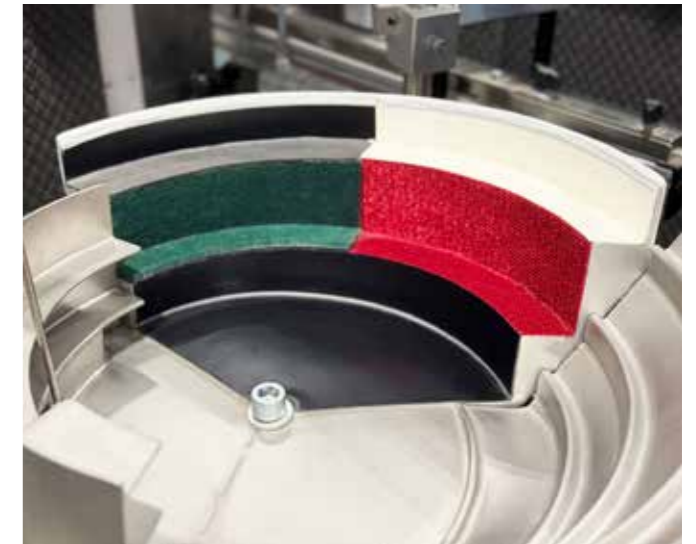

Coating material	Properties	Areas of application
Polyurethane film - smooth / rough 1 mm coat thickness Colour: black	<ul style="list-style-type: none"> <li>High strength</li> <li>Excellent soundproofing</li> <li>Both sides can be glued (using the smooth or the rough side as running surface)</li> <li>Rough running surface suitable for slightly moist parts,</li> </ul>	Dry and clean metal parts and heavy plastic parts
Polyurethane film - smooth / rough 2 mm coat thickness Colour: black	<ul style="list-style-type: none"> <li>Same as above, plus:</li> <li>Very high resistance to wear</li> <li>Abrasion-resistant</li> <li>Impact-resistance, excellent soundproofing</li> </ul>	Same as above, plus: heavy, sharp-edged metal, glass parts and abrasive parts, such as screws, forged and stamped parts
Polyurethane film, fluted Colour: black	<ul style="list-style-type: none"> <li>Oil can drain off via the flutes</li> </ul>	Oily, wet and sticky parts (stamped parts, screw blanks)
Habasit film (HAM-5P) Colour: green  Food-grade version Colour: white	<ul style="list-style-type: none"> <li>Good feeding performance even with slight liquid films</li> <li>Minor static charging of plastic parts, the side wall is coated with polyurethane film (1mm thick)</li> </ul>	Parts with smooth surfaces, lightweight plastic parts, slightly oily parts (drawing oil, parting agent)
Brush coating	<ul style="list-style-type: none"> <li>Oily parts</li> <li>Gentle part handling</li> <li>Noise reduction</li> </ul>	Screw blanks, heavy metal parts, parts with sensitive surfaces
Flock coating Textile surface	<ul style="list-style-type: none"> <li>Gentle part handling</li> <li>Increase of feed rate</li> </ul>	Lightweight parts with sensitive surfaces
Metaline	<ul style="list-style-type: none"> <li>Wear resistant surface covers joints</li> <li>Adjustable hardness and surface</li> <li>Various colours available</li> </ul>	Light to medium-heavy plastic and metal parts with dry surfaces, pharmaceutical industry: FDA-approved

# Vibratory feeder decision matrix

Size	100	150	160	200	250	400	630	800
Cylindrical bowls Stainless steel sheet			ZSB-Z 160-12-70	ZSB-Z 200-12-80	ZSB-N 250-30-110 ZSB-ZA 250-30-125	ZSB-N 400-30-160 ZSB-BA 400-30-175 ZSB-ZA 400-30-190	ZSB-N 630-50-180 ZSB-BA 630-50-195	ZSB-B 800-80-220
Conical bowls Stainless steel sheet				KSB-Z 200-18-55 KSB-ZA 200-5RG-150	KSB-N 250-20-90 KSB-ZA 250-20-105 KSB-ZA 250-20-150 KSB-ZA 250-8RG-150	KSB-N 400-50-160 KSB-BA 400-50-175 KSB-BA 400-15RG-220 KSB-ZA 400-50-190 KSB-ZA 400-15RG-235	KSB-N 630-50-180 KSB-BA 630-50-190 KSB-BA 630-15RG-250	KSB-B 800-80-170
Stepped bowls Cast aluminium				TAG-Z 200-10-80 TAG-Z 200(324)-20-105	TAG-N 250-20-105 TAG-N 250-32-130 TAG-N 250-32-145 TAG-ZA 250-32-165 TAG-ZA 250(541)-32-180	TAG-N 400-32-175 TAG-N 400-50-190 TAG-N 400-50-215 TAG-ZA 400-50-240	TAG-N 630-50-220 TAG-N 630-65-230 TAG-ZA 630-50-240 TAG-ZA 630-65-250	
Plastic bowls milled			KKF-Z 160-X-65 TKF-Z 160-X-65	KKF-Z 200-X-65 TKF-Z 200-X-65	KKF-ZA 250-X-100 TKF-ZA 250-X-100	on request		
Plastic bowls printed	KKD-Z 100	KKD-Z 150		KKD-Z 200				
Fixed bowl centre					SRF-N 250(PA) SRF-N 250(AL) SRF-N 250(VA)	SRF-N 400(PA) SRF-N 400(AL) SRF-N 400(VA)	SRF-N 630(PA) SRF-N 630(VA)	
Loose bowl centre					SRL-N 250(PA) SRL-N 250(AL)	SRL-N 400(PA) SRL-N 400(AL)	SRL-N 630(AL)	
Adapter plates					AAG-Z 250	AAG-R 400 AAG-R400(544) SA AAG-Z 400 AAG-Z 400(Z) AAG-Z 400(250)SA	AAG-ZB 630 AAG-R 630 AAG-R 630(666)SA	
Drives	SRA-Z 100-2	SRA-Z 150-2	SRC-N 160-2	SRC-N 200-2 SRC-B 200-2 SRA-Z 200-2	SRC-N 250-2 SRC-B 250-2	SRC-N 400-2 SRC-N 400-1 SRHL 400-2 SRHL 400-1	SRC-N 630-1	SRC-N 800-1
Baseplates			SRG-200 USJ-200	SRG-200 USJ-200	SRG-250 USJ-250	SRG-400 USJ-400	SRG-630 USJ-630	
Mounting plates					UP 250	UP 400	UP 630	
Longitudinal slides					UL 250	UL 400	UL 630	
Cross-slides					UK 250	UK 400	UK 630	
Substructure with threaded column					UG 400-535 UG 400-735 UG 400-935	UG 630-535 UG 630-735 UG 630-935	UG 630-535 UG 630-735 UG 630-935	
Sound enclosures					HK-S 250	HK-S 400	HK-S 630	
Stand-alone mounting Phase control	SCU 1000 SCU 2000 ESG 2000 ESK 2000 ESK 2001 ESK 2002	SCU 1000 SCU 2000 ESG 2000 ESK 2000 ESK 2001 ESK 2002	SCU 1000 SCU 2000 ESG 2000 ESK 2000 ESK 2001 ESK 2002	SCU 1000 SCU 2000 ESG 2000 ESK 2000 ESK 2001 ESK 2002	SCU 1000 SCU 2000 ESG 2000 ESK 2000 ESK 2001 ESK 2002	SCU 1000 SCU 2000 ESG 2000 ESK 2000 ESK 2001 ESK 2002	SCU 1000 SCU 2000 ESG 2000 ESK 2000 ESK 2001 ESK 2002	ESG 2000 ESK 2000
Stand-alone mounting Variable frequency control	SCF 2000 SCF 3000 6A ESR 2000 ESR 2500 ESR 3000/6A	SCF 2000 SCF 3000 6A ESR 2000 ESR 2500 ESR 3000/6A	SCF 2000 SCF 3000 6A ESR 2000 ESR 2500 ESR 3000/6A	SCF 2000 SCF 3000 6A ESR 2000 ESR 2500 ESR 3000/6A	SCF 2000 SCF 3000 6A ESR 2000 ESR 2500 ESR 3000/6A	SCF 2000 SCF 3000 6A ESR 2000 ESR 2500 ESR 3000/6A	SCF 2000 SCF 3000 6A ESR 2000 ESR 2500 ESR 3000/6A	ESR 3000/12A ESR 2800
Panel-mounting Phase control	ESM 906	ESM 906	ESM 906	ESM 906	ESM 906	ESM 906 ESM 910*	ESM 906	ESM 910
Panel-mounting Variable frequency control	SCF 3000M 6A	SCF 3000M 6A	SCF 3000M 6A	SCF 3000M 6A	SCF 3000M 6A	SCF 3000M 6A	SCF 3000M 6A	SCF 3000M 6A

Bowl shape	Material	Size	Spiral track width (mm)	Bowl height	Feeding direction
C = cylindrical	A = aluminium		X = variable width of spiral track	from mounting surface	r = to right (clockwise) l = to left (anticlockwise)
K = conical	S = steel				
T = stepped	K = plastic				

K S B - ZA - 250 - 8 (RG) - 150 R

Method of manufacture	Bowl centre/fastening variants	Spiral shape
B = steel sheet construction	N = "nothing" - additional bowl centre required	R = right-angled
D = turned	Z = central attachment with welded or cast bowl centre	G = closed
F = milled	B = welded bowl centre	
G = cast	A = adapter plate	
	2A = additional adapter plate for central fastening	

Please specify the feeding direction when ordering the bowls or drives.

\* only for drives upwards of 6 A

# RNA's Linear Feeders

Linear feeders permit linear sorting (linear sorting section). Such sorting sections can also be installed in the form of multiple lanes to achieve higher selection performance. Rejected parts are returned to the upstream feeding system via so-called sorting trays which are also operated by the linear feeder. In addition to purely feeding, linear feeders also act as buffering and accumulation section, allowing you to supply a continuous stream of parts to the downstream process even if parts arrive in discontinuous manner from the upstream sorting system. Linear feeders also serve as drives for hopper trays used to store bulk products. In comparison to other hopper systems, vibratory hoppers offer the design-inherent advantage of guaranteeing trouble-free and gap-less material flow, and accommodate high loading weights. For more information, please refer to the chapter titled "Hoppers". Linear feeders from RNA achieve high feeding rates and do their jobs even with long feeding sections or in critical conditions.



# Selection matrix for two-mass linear feeders with rubber-metal isolators

This is an overview of the best-selling linear feeders from our program. These units are mounted on the baseplates via vibration isolators. We offer a standard version and also different adaptations.

When selecting the adaptation, be sure to consider that harder isolators will also transmit more vibrations into the substructures.

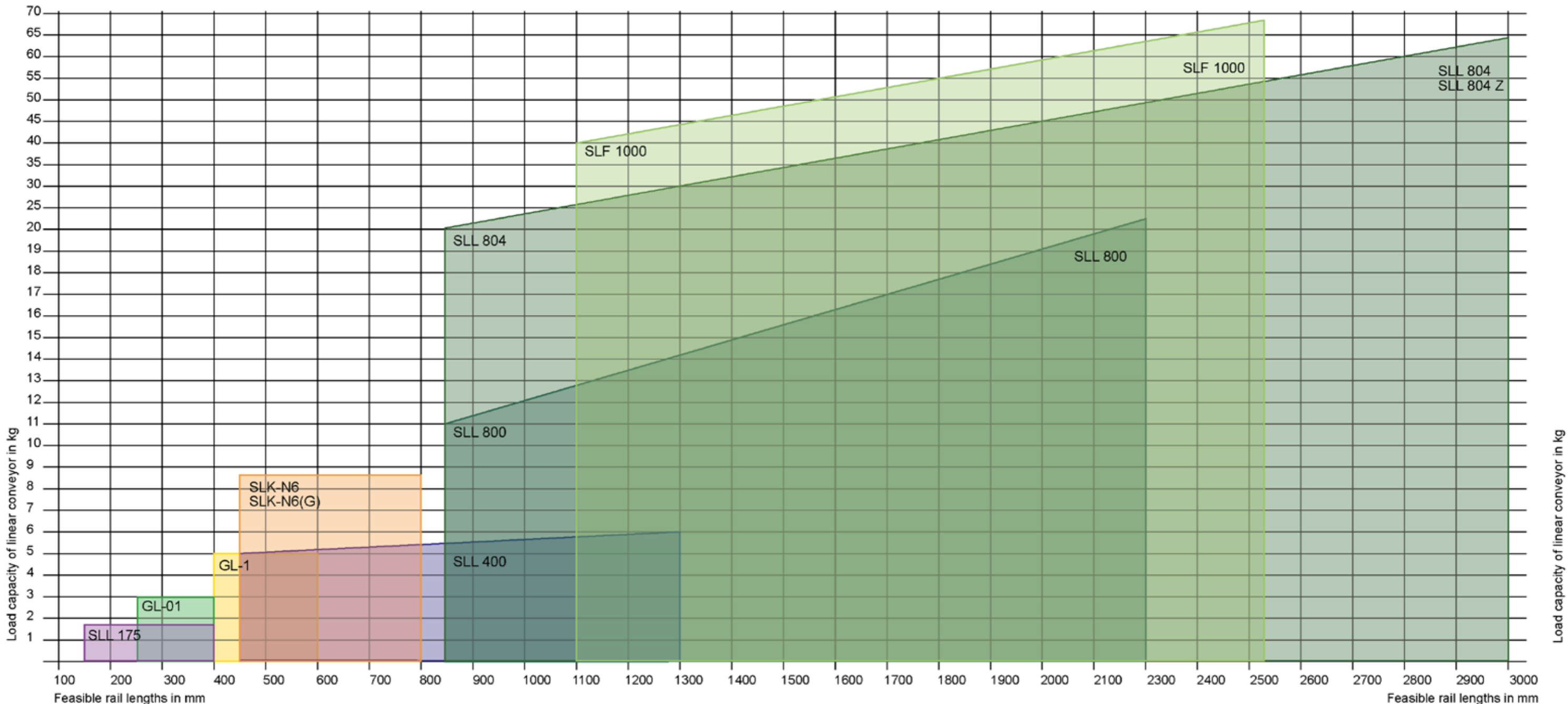

# Linear feeder series SLL 175



### Infos

- In their standard version, linear feeders of the SLL 175 series are equipped with 200V / 50Hz magnets.
- Also available with : 200V 60Hz, 110V 50Hz, 110V 60Hz
- Protection rating IP 54
- CE and CSA/UL
- Suitable for rail lengths from 175 mm to 400 mm, with max. weight from 1.3 kg to 1.5 kg
- The aluminium sections receiving the top-mounted components can be installed in two positions. This results in different fastener hole pitches:  
B = 48 mm and S = 20 mm

### Description

Linear feeders of the SLL 175 family have been designed for use as linear accumulating feeders in small, compact feeding systems.

All linear feeders of RNA's SLL series are noted for two characteristic features:

1. Patented adjustment of the spring angles where the set air gap is preserved and the rail's position in relation to the substructure is maintained.
2. Swappable vibrating sections

Width extenders and substructures are available as accessories.

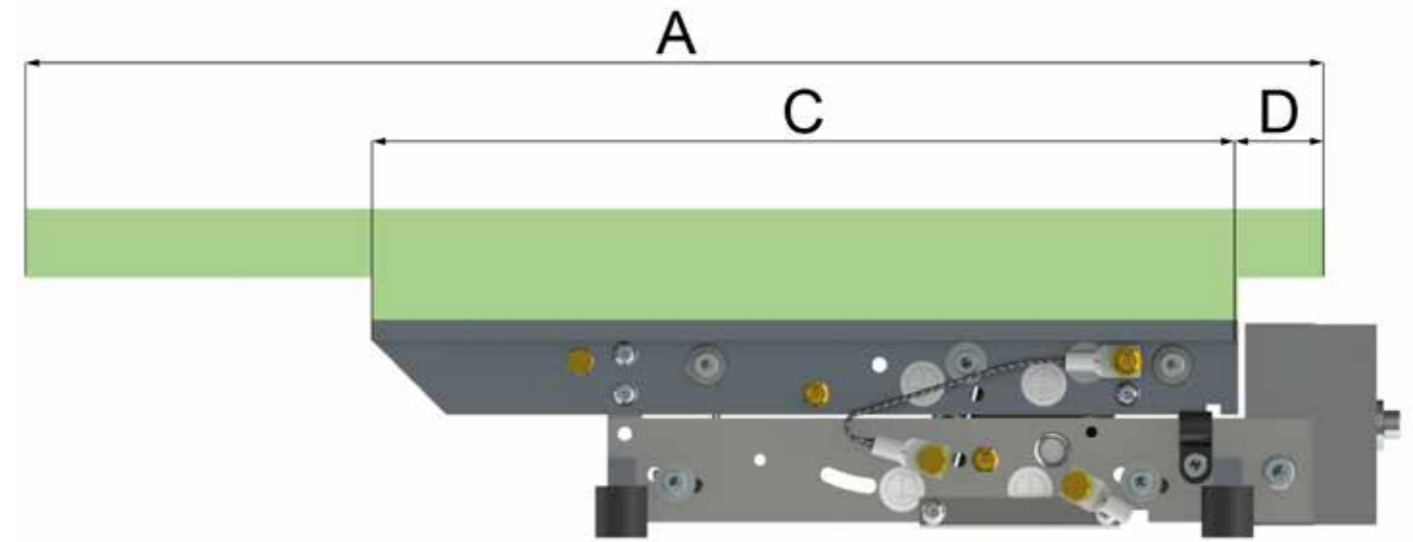

Typical application: SLL 175-250 as accumulation section for feeding to an escapement

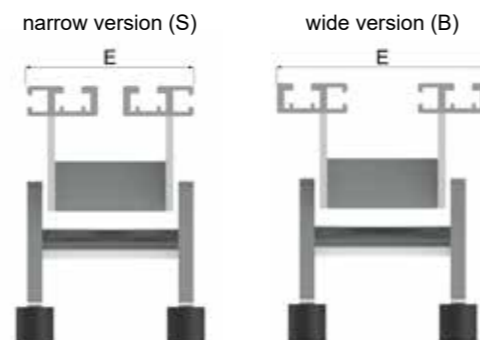

Type	SLL 175-175	SLL 175-250
Dimensions LxWxH (mm)	200x82x63	275x82x63
A = maximum rail length (mm)	325	400
C = length of vibratory unit (mm)	175	250
D = max. rail overhang (entry end) (mm)	50	50
E = width of vibratory unit (s / b) (mm)	36 / 62	36 / 62
Weight of linear feeder (kg)	1.2	1.4
Max. weight of vibratory units, linear rail and fastening components (kg)	1.3	1.5
Max. weight of all parts lying on the rail (kg)	0.5	0.6
Current input (mA)	70	70
Vibrating frequency (Hz)	100	100
Connecting cable length (m)	1.5	1.5

# Linear feeder series SLL 400



### Infos

- In their standard version, linear feeders of the SLL 400 series are outfitted with 200V / 50Hz magnets.
- Also available with : 200V 60Hz, 110V 50Hz, 110V 60Hz
- Protection rating IP 54
- CE and CSA/UL
- Suitable for rail lengths from 400 mm to 1,300 mm, with max. weight from 5 kg to 8 kg
- The aluminium sections for fastening of top-mounted components can be installed in two positions. This results in different fastener hole pitches:  
**B = 64 mm and S = 30 mm**

### Description

Linear feeders of the SLL 400 series have been primarily designed to serve as linear accumulating sections in feeding systems, however they can also be used to build compact vibration hoppers.

A vibrating section with continuous slot specially made for these linear feeders permits easy mounting of sorting rails or hopper trays.

All linear feeders of RNA's SLL series are noted for two characteristic features:

1. Patented adjustment of the spring angles where the set air gap is preserved and the rail's position in relation to the substructure is maintained.
2. Swappable vibrating sections

Width extenders and substructures are available as accessories.

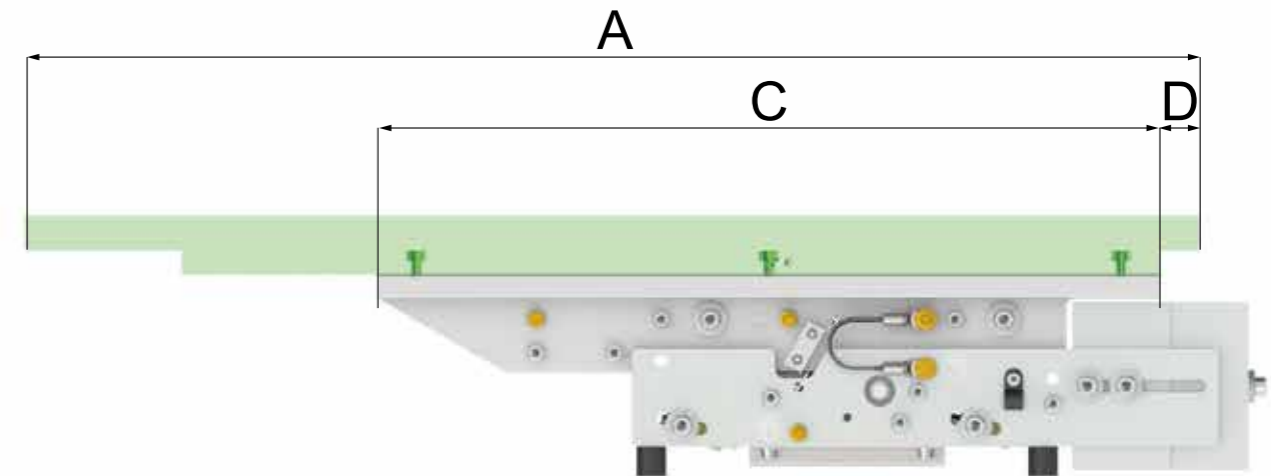

Typical application: Orienting section based on SLL 400

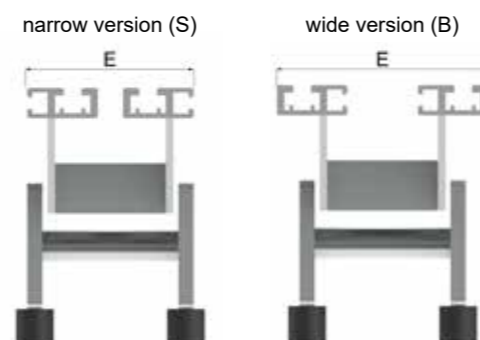
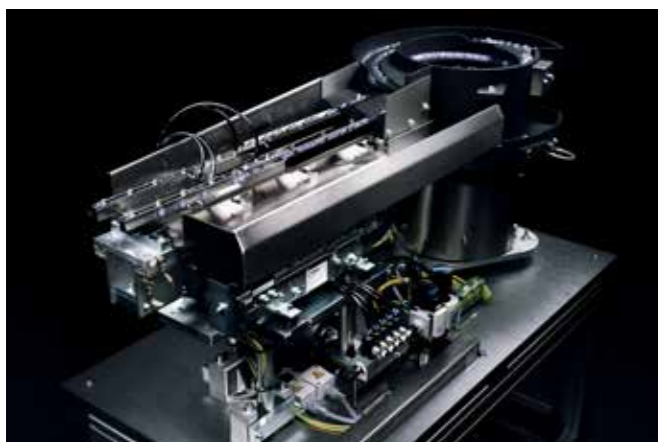

Type	SLL 400-400	SLL 400-600	SLL 400-800	SLL 400-1000
Dimensions LxWxH (mm)	430x84x103	630x84x103	830x84x103	1030x84x103
A - maximum rail length (mm)	700	900	1100	1300
C - length of vibratory unit (mm)	400	600	800	1000
D - max. rail overhang (entry end) (mm)	100	100	100	100
E - width of vibratory unit (s / b) (mm)	66 / 84	66 / 84	66 / 84	66 / 84
Weight of linear feeder (kg)	6.5	8	10	12.5
Max. weight of vibratory units, linear rail and fastening components (kg)	5	6	7	8
Recommended weight of all parts lying on the rail (kg)	2	2	2	2
Current input (mA)	600	600	600	600
Vibrating frequency (Hz)	100	100	100	100
Connecting cable length (m)	1.5	1.5	1.5	1.5

# Linear feeder series SLL 800

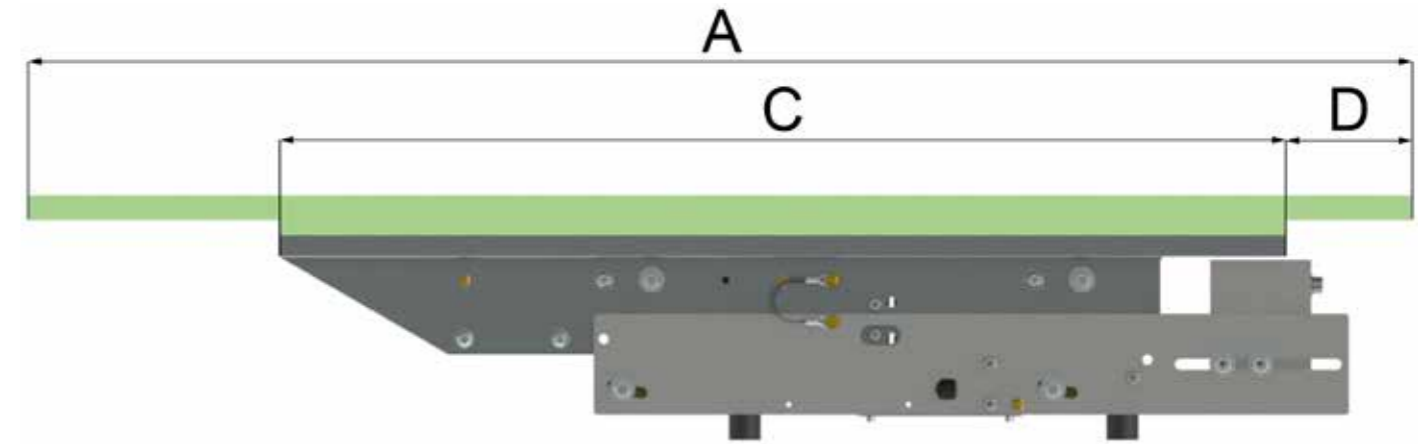

### Infos

- In their standard version, linear feeders of the SLL 800 series are outfitted with 200V / 50Hz magnets.
- Also available with : 200V 60Hz, 110V 50Hz, 110V 60Hz
- Protection rating IP 54
- CE and CSA/UL
- Suitable for rail lengths from 800 mm to 2,300 mm, with max. weight from 11 kg to 23 kg
- The aluminium sections for fastening of top-mounted components can be installed in two positions. This results in different fastener hole pitches:  
**B = 90 mm and S = 40 mm**

### Description

Linear feeders of the SLL 800 series have been primarily designed to serve as linear accumulating sections in feeding systems, however they can also be used to build compact vibration hoppers.

A vibrating section with continuous slot specially made for these linear feeders permits easy mounting of sorting rails or hopper trays.

All linear feeders of RNA's SLL series are noted for two characteristic features:

1. Patented adjustment of the spring angles where the set air gap is preserved and the rail's position in relation to the substructure is maintained.
2. Swappable vibrating sections

Width extenders and substructures are available as accessories.

Typical application: SLL 800-1200 as accumulation section

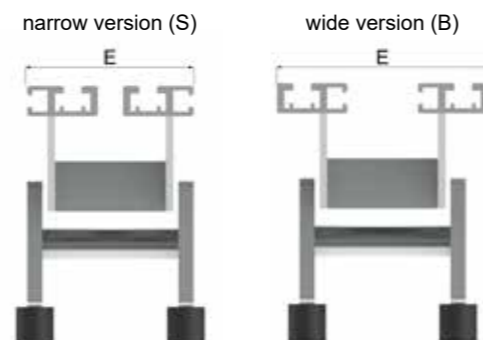

Type	SLL 800-800	SLL 800-1000	SLL 800-1200	SLL 800-1400	SLL 800-1600	SLL 800-1800	SLL 800-2000
Dimensions LxWxH (mm)	850x120x162	1050x120x162	1250x120x162	1450x120x162	1650x120x162	1850x120x162	2050x120x162
A = maximum rail length (mm)	1100	1300	1500	1700	1900	2100	2300
C = length of vibratory unit (mm)	800	1000	1200	1400	1600	1800	2000
D = max. rail overhang (entry end) (mm)	100	100	100	100	100	100	100
E = width of vibrating unit (s / b) (mm)	70 / 120	70 / 120	70 / 120	70 / 120	70 / 120	70 / 120	70 / 120
Weight of linear feeder (kg)	18.5	20.5	23.5	24	31.5	34	39.5
Max. weight of vibratory units, linear rail and fastening components (kg)	11	13	15	17	19	21	23
Max. weight of all parts lying on the rail (kg)	8	8	10	10	10	10	10
Current input (mA)	1260	1260	1260	1260	1260	1260	1260
Vibrating frequency (Hz)	50	50	50	50	50	50	50
Connecting cable length (m)	1.75	1.75	1.75	1.75	1.75	1.75	1.75

# Linear feeder series SLL 804



### Infos

- In their standard version, linear feeders of the SLL 804 series are outfitted with 200V / 50Hz magnets.
- Also available with : 200V 60Hz, 110V 50Hz, 110V 60Hz
- Protection rating IP 54
- CE and CSA/UL
- Suitable for rail lengths from 800 mm to 3,100 mm, with max. weight from 21 kg to 62 kg
- The aluminium sections for fastening of top-mounted components can be installed in two positions. This results in different fastener hole pitches:  
**B = 90 mm and S = 40 mm**

### Description

Linear feeders of the SLL 804 series are the heavy-duty version of SLL 800 feeders, and have been specially developed to meet the need for large and heavy accumulating sections. The higher weight combined with the configuration of the magnet provides users with a high performance spectrum.

A vibrating section with continuous slot specially made for these linear feeders permits easy mounting of sorting rails or hopper trays.

All linear feeders of RNA's SLL series are noted for two characteristic features:

1. Patented adjustment of the spring angles where the set air gap is preserved and the rail's position in relation to the substructure is maintained.

2. Swappable vibrating sections

Width extenders and substructures are available as accessories.

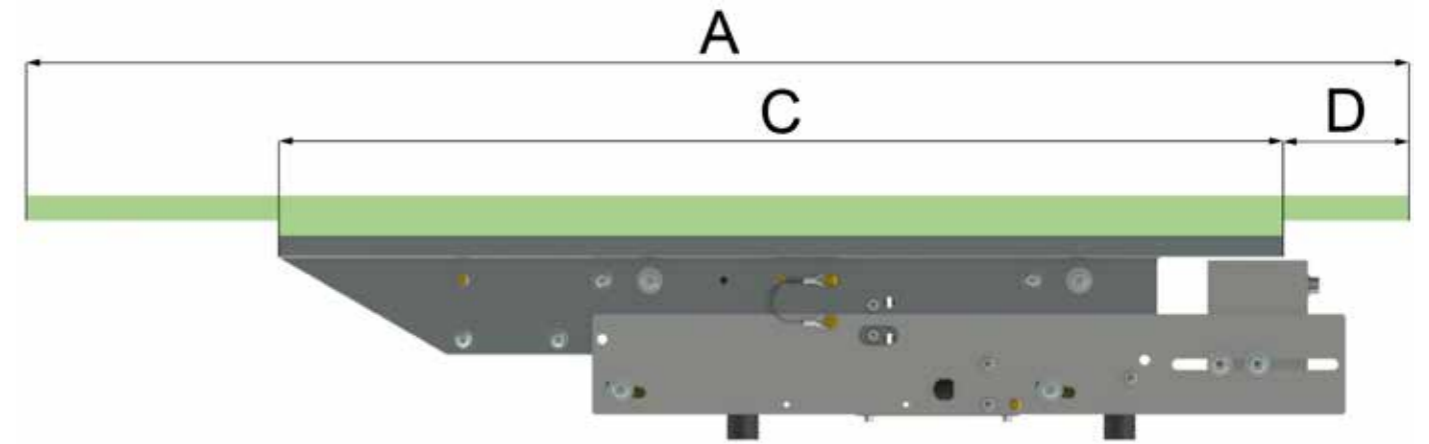

Typical application: SLL 804 as accumulation and feeding section

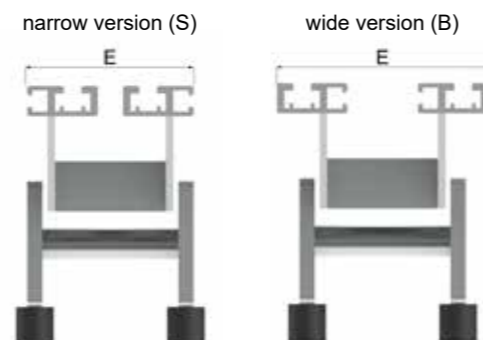

Type	SLL 804-800	SLL 804-1000	SLL 804-1200	SLL 804-1400	SLL 804-1600	SLL 804-1800	SLL 804-2000	SLL 804-2400	SLL 804-2800
Dimensions LxWxH (mm)	850x127x172	1050x127x172	1250x127x172	1450x127x172	1650x127x172	1850x127x172	2050x127x172	2450x127x172	2850x127x172
A = maximum rail length (mm)	1100	1300	1500	1700	1900	2100	2300	2700	3100
C = length of vibratory unit (mm)	800	1000	1200	1400	1600	1800	2000	2400	2800
D = max. rail overhang (entry end) (mm)	100	100	100	100	100	100	100	100	100
E = width of vibratory unit (s / b) (mm)	70 / 120	70 / 120	70 / 120	70 / 120	70 / 120	70 / 120	70 / 120	70 / 120	70 / 120
Weight of linear feeder (kg)	21.5	24.5	27.5	29.5	39.5	43	49.5	63	76
Max. weight of vibratory units, linear rail and fastening components (kg)	21	25	28	32	36	40	44	51	62
Max. weight of all parts lying on the rail (kg)	15	15	15	15	15	15	15	12	12
Current input (mA)	1260	1260	1260	1260	2510	2510	2510	2510	2510
Vibrating frequency (Hz)	50	50	50	50	50	50	50	50	50
Connecting cable length (m)	1.75	1.75	1.75	1.75	1.75	1.75	1.75	1.75	1.75

# Linear feeder series SLL 804 Z

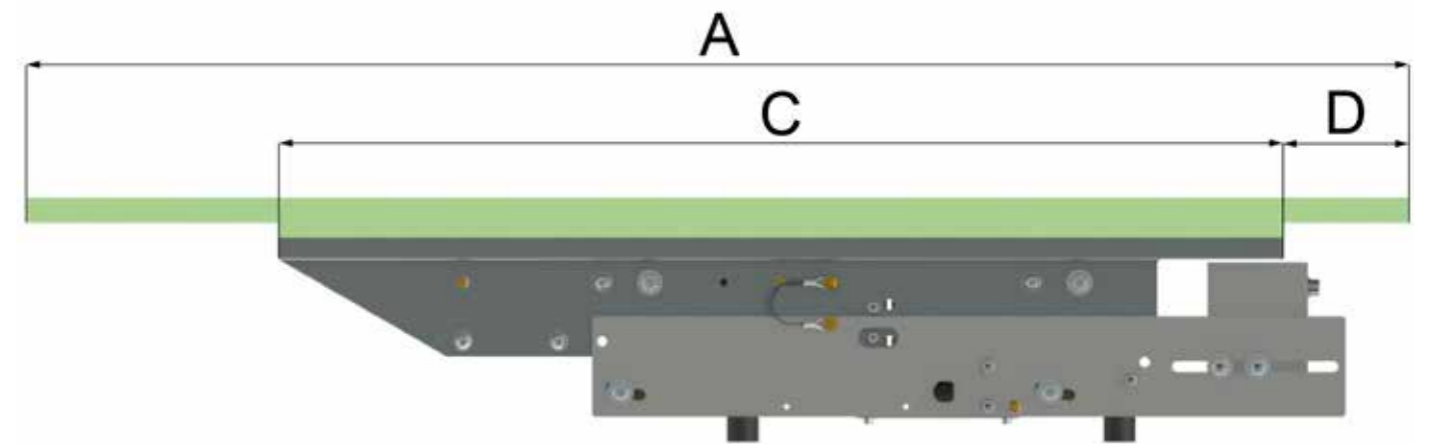

### Infos

- In their standard version, linear feeders of the SLL 804 Z series are outfitted with 200V / 50Hz magnets.
- Also available with : 200V 60Hz, 110V 50Hz, 110V 60Hz
- Protection rating IP 54
- CE and CSA/UL
- Suitable for rail lengths from 800 mm to 3,100 mm, with max. weight from 21 kg to 62 kg
- The aluminium sections for fastening of top-mounted components can be installed in two positions. This results in different fastener hole pitches:  
**B = 90 mm and S = 40 mm**

### Description

Linear feeders of the SLL 804 Z series present the same characteristics and dimensions as the SLL 804 series feeders. But this series comes with a higher number of spring packs. This feature is helpful when the drive is to be operated with high amplitudes. The additional spring force required for this is distributed onto more spring packs.

Typical application: SLL 804 Z-1600 as accumulation and feeding section in the pharmaceutical industry

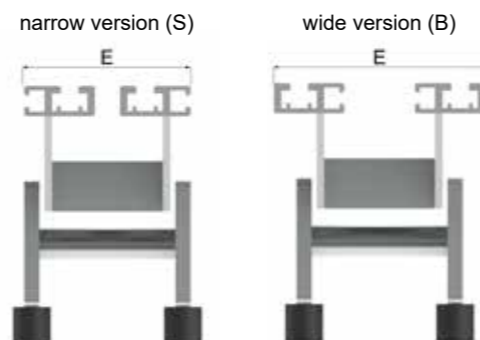

Type	SLL 804 Z-800	SLL 804 Z-1000	SLL 804 Z-1200	SLL 804 Z-1400	SLL 804 Z-1600	SLL 804 Z-1800	SLL 804 Z-2000	SLL 804 Z-2400	SLL 804 Z-2800
Dimensions LxWxH (mm)	850x127x172	1050x127x172	1250x127x172	1450x127x172	1650x127x172	1850x127x172	2050x127x172	2450x127x172	2850x127x172
A - maximum rail length (mm)	1100	1300	1500	1700	1900	2100	2300	2700	3100
C - length of vibratory unit (mm)	800	1000	1200	1400	1600	1800	2000	2400	2800
D - max. rail overhang (entry end) (mm)	100	100	100	100	100	100	100	100	100
E - width of vibrating unit (s / b) (mm)	70 / 120	70 / 120	70 / 120	70 / 120	70 / 120	70 / 120	70 / 120	70 / 120	70 / 120
Weight of linear feeder (kg)	21.5	24.5	27.5	29.5	39.5	43	49.5	63	76
Max. weight of vibratory units, linear rail and fastening components (kg)	21	25	28	32	36	40	44	51	62
Max. weight of all parts lying on the rail (kg)	15	15	15	15	15	15	15	12	12
Current input (mA)	1260	1260	1260	1260	2510	2510	2510	2510	2510
Vibrating frequency (Hz)	50	50	50	50	50	50	50	50	50
Connecting cable length (m)	1.75	1.75	1.75	1.75	1.75	1.75	1.75	1.8	1.8

# Linear feeder series SLF 1000



### Infos

- In their standard version, linear feeders of the SLL 1000 series are outfitted with 200V / 50Hz magnets.
- Also available with : 200V 60Hz, 110V 50Hz, 110V 60Hz
- Protection rating IP 54
- CE and CSAUL. Suitable for rail lengths from 800 mm to 3,100 mm, with max. weight from 21 kg to 62 kg
- The aluminium sections for fastening of top-mounted components can be installed in two positions. This results in different fastener hole pitches:  
B = 204 mm and S = 140 mm

### Description

Linear feeders of RNA's SLF 1000 series are chosen when vibrating units represent a big weight (approx. 50 kg) and high amplitudes are required. These drives enable rail lengths from 1,000 - 3,000 mm to be realized with proven process reliability. These drives - in combination with variable frequency controllers - are also perfect for vibratory hoppers with a loading capacity of 200 kg.

Feeders of the SLF 1000 series present the same characteristics as the SLL series.

Width extenders and substructures are available as accessories.

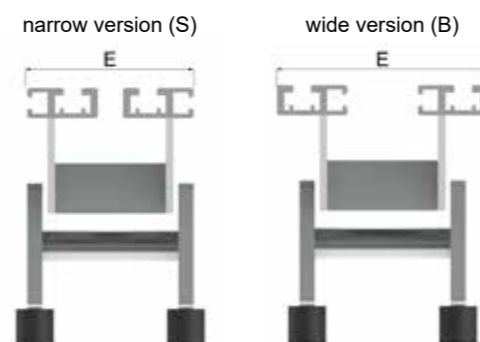
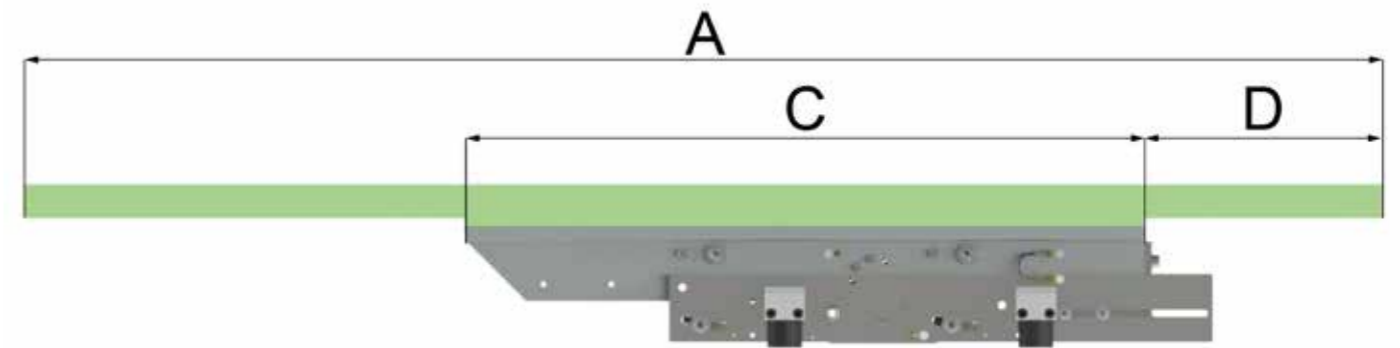

Type	SLF 1000-1000	SLF 1000-1500
Dimensions LxWxH (mm)	1100x244x178	1600x244x178
A = maximum rail length (mm)	2000	2500
C = length of vibratory unit (mm)	1000	1500
D = max. rail overhang (entry end) (mm)	350	350
E = width of vibratory unit (s / b) (mm)	204 / 244	204 / 244
Weight of linear feeder (kg)	62	80
Max. weight of vibratory units, linear rail and fastening components (kg)	35	65
Max. weight of all parts lying on the rail (kg)	20	20
Current input (mA)	2500	5000
Vibrating frequency (Hz)	50	50
Connecting cable length (m)	1.75	1.75

# Linear feeder series SLC 300 / 500

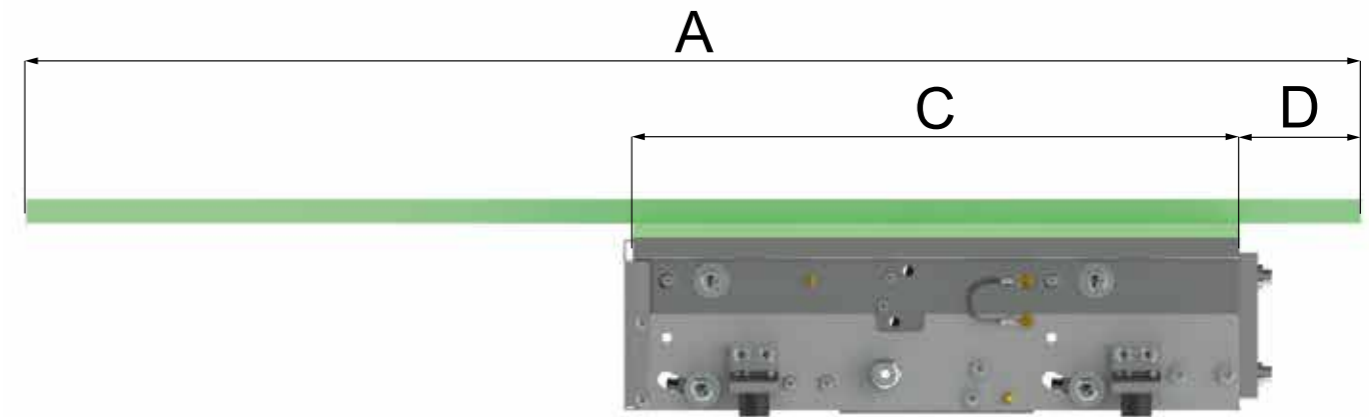
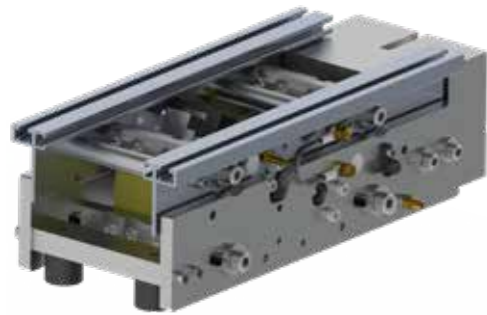

### Infos

- **Even conveyance of pills or bottles**
- **Accelerated discharge at exit end**
- **Compact design for integration with customer's machine**
- **Compact linear feeder with 50Hz magnets**
- **Low height**
- **Shortest possible length**
- **Very high load carrying capacity possible (approx. 60-70 kg)**
- **Big overhangs can be realized at the exit end (approx. 500 - 700 mm)**
- **Minimum transmission of vibrations into the baseframe at high amplitudes, due to the drive weight**
- **Vibration isolator arrangement (8-part)**
- **The spring arrangement in combination with the counterweight provides for smooth and gentle running behaviour (for feeding of glass bottles in upright position, for example)**
- **Adjustable spring angles**
- **The SLC500 linear feeders have an overall length of 525 mm.**
- **The second figure in the type designation indicates the hole pitch over the width of the linear feeder. These holes serve to fasten the top-mounting components.**

### Description

The new linear feeders of the SLC series are ideal for applications with wide, multi-lane transport and accumulation sections as well as for the realization of hopper systems where a high filling volume and weight must be achieved in a small space. The concept of the SLC series is based on the use of 2 magnets arranged in parallel, which effectively distribute their force over 4 leaf spring assemblies. Depending on the drive type, payloads of up to 100 kg are possible as a bunker drive, for example. Depending on the design, accumulation sections can also be mounted with a weight of up to 40 kg. The even and gentle vibration transmission can be optimized by the user via the adjustable spring angle installation and weight adjustment. We recommend operating the drives with our ESR and SCF frequency controls

Type	SLC 300-140	SLC 500-200	SLC 500-300	SLC 500-400
Dimensions LxWxH (mm)	300x140x105	525x369x148	525x469x148	525x569x148
A = maximum rail length (mm)	600	1000	1000	1000
C = length of vibratory unit (mm)	300	500	500	500
D = max. rail overhang (entry end) (mm)	100	100	100	100
E = width of vibratory unit (s / b) (mm)	140	220	320	420
Weight of linear feeder (kg)	15	40	40	50
Max. weight of vibratory units, linear rail and fastening components (kg)	15	40	50	60
Max. weight of all parts lying on the rail (kg)	2	2	2	2
Current input (mA)	1200	2520	2520	2520
Vibrating frequency (Hz)	100	50	50	50
Connecting cable length (m)	2	2	2	2

# Linear feeder series SLK

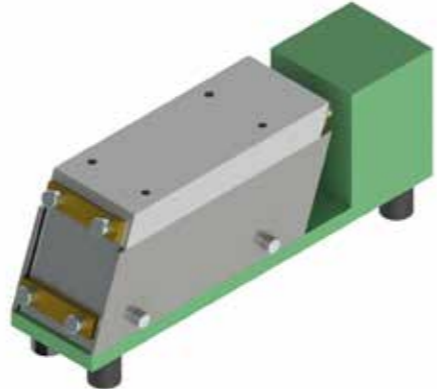

- Infos**
- **Compact design**
  - **Easy spring replacement**

**Description**  
 Linear feeders of RNA's SLK series are designed to drive vibrating troughs in which bulk product is conveyed. They serve for linear transfer as well as correctly oriented and metered feeding of bulk parts.



Fig.: SLK N6 (G)

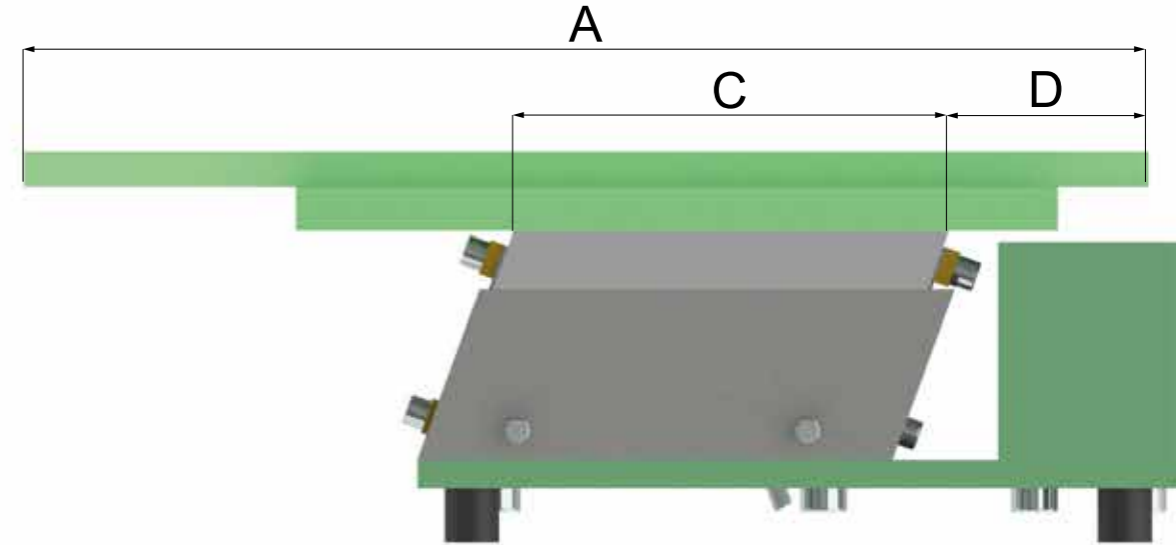

Fig.: SLK 05

Type	SLK 05	SLK 1	SLK N6	SLK N6 (G)	SLK 12
Dimensions LxWxH (mm)	210x50x86	305x123x104	426x162x143	598x162x143	515x203x164
A = maximum rail length (mm)	350	400	800	800	1000
C = length of vibratory unit (mm)	120	247	340	340	415
D = max. rail overhang (entry end) (mm)	50	50	150	150	190
Width of vibratory unit (mm)	45	123	162	162	203
Weight of linear feeder (kg)	2.8	8	22.3	35	33
Max. weight of vibratory units, linear rail and fastening components (kg)	1	3.5	8	10	20
Max. weight of all parts lying on the rail (kg)	0.5	3	5	7	10
Current input (mA)	70	200	1250	1250	2200
Vibrating frequency (Hz)	100	100	50	50	50
Connecting cable length (m)	1.5	1.5	1.5	1.5	1.5

The design difference between rail length and vibratory unit length should observe following ratio:  
 1/3rd at entry end and 2/3rds at exit end

# Linear feeder series GL



### Infos

- In their standard version, GL1 and GL01-size linear feeders are outfitted with 200V / 50Hz magnets.
- Also available with : 200V / 60 Hz, 110V / 60 Hz
- Protection rating IP 54
- CE and CSA/UL

### Description

RNA's linear feeders of the GL family are outfitted with horizontally mounted springs. Their feeding behaviour resembles more a sliding than the skipping that is typical for linear feeders. This characteristic offers big advantages, especially for realizing interface transitions with small parts, as the small relative movements between upstream and downstream equipment cause no problems.

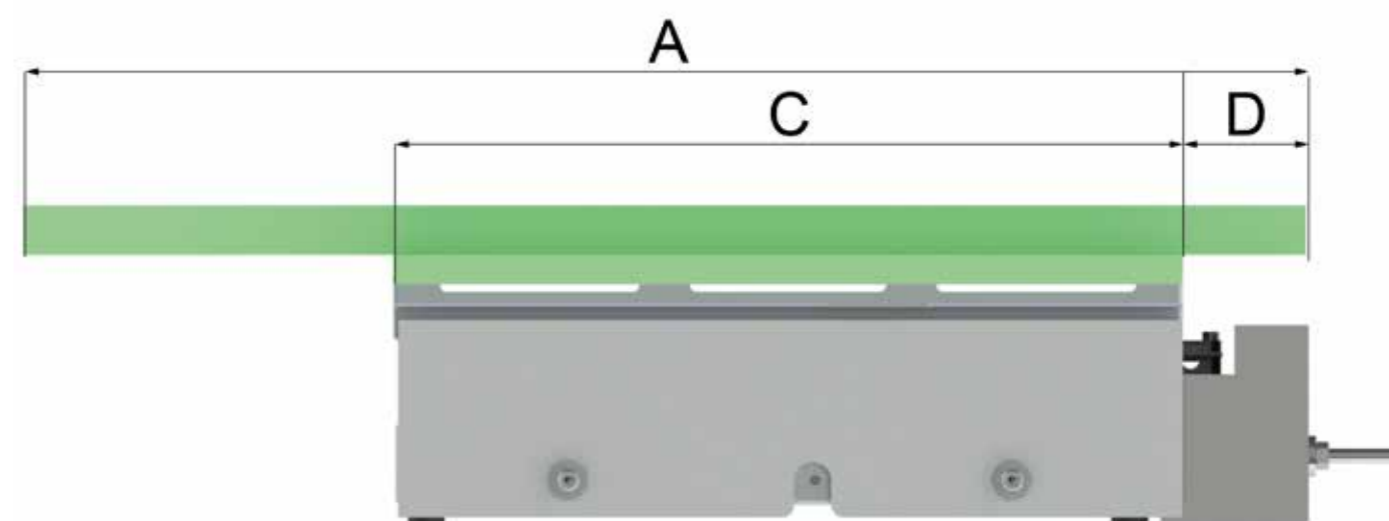

Type	GL 01	GL 1
Dimensions LxWxH (mm)	245x78x100	410x117x100
A = maximum rail length (mm)	400	600
C = length of vibratory unit (mm)	170	320
D = max. rail overhang (entry end) (mm)	70	90
E = width of vibratory unit (s / b) (mm)	58	105
Weight of linear feeder (kg)	3.8	8.5
Max. weight of vibratory units, linear rail and fastening components (kg)	2.5	4.5
Max. weight of all parts lying on the rail (kg)	0.5	1
Current input (mA)	600	870
Vibrating frequency (Hz)	100	100
Connecting cable length (m)	1.4	1.4

# Selection matrix for two-mass linear feeders without rubber-metal isolators

The following pages show linear feeders for installation without vibration isolators. The linear feeder types mentioned below are bolted down on the equipment. This facilitates the passage to downstream part handling equipment. The vibrations generated are absorbed by the unit, so that only very few of them are transferred into the substructures.

These units can be tuned with the computer-based simulation program called "Digital Motion". For control, we recommend the use of variable frequency controllers. At this time, there are only isolator-less linear feeders that work in full-wave mode and with a vibrating frequency around 100/120 Hz.

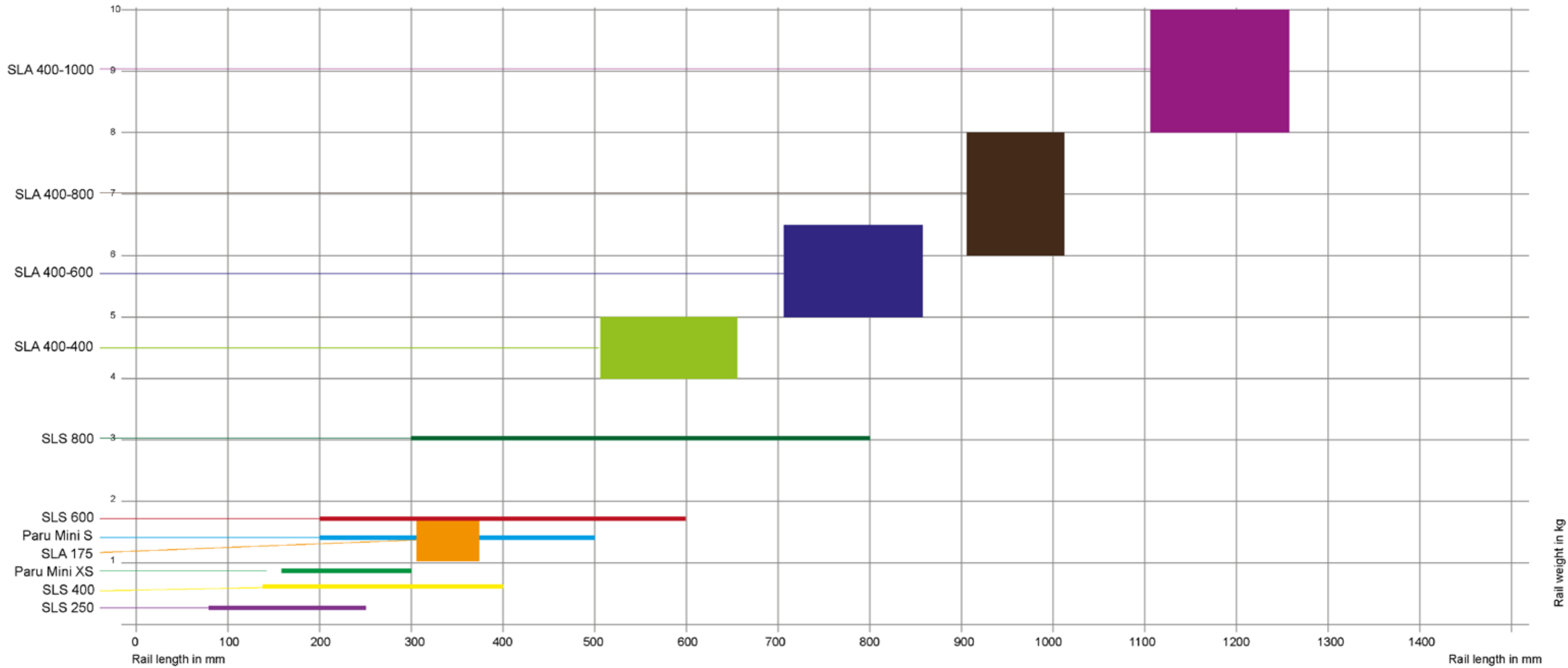

# Linear feeder series SLA



### Infos

- **These linear feeders are rated and dimensioned for high rail weights and very different rail lengths.**
- **Rail lengths start at 375 mm and can go up to 1,250 mm.**
- **The weight of the rail should correspond to the specifications from the table.**
- **SLA linear feeders only come with 200V / 50 Hz magnets.**

### Description

SLA-type linear feeders establish a precise and defined connection with vibratory feeders, linear feeders or escapements. The fixed-mounted linear feeder offers a uniform running behaviour regardless of the mass of the substructures. Also, it doesn't pick up any influences from the environment. Cross-vibrations are eliminated, providing for stable transitions with reliable guidance, especially for critical part geometries. The fixed-mounted base has no spring elements, adjusting holes allow for easy positioning against the feed rail.

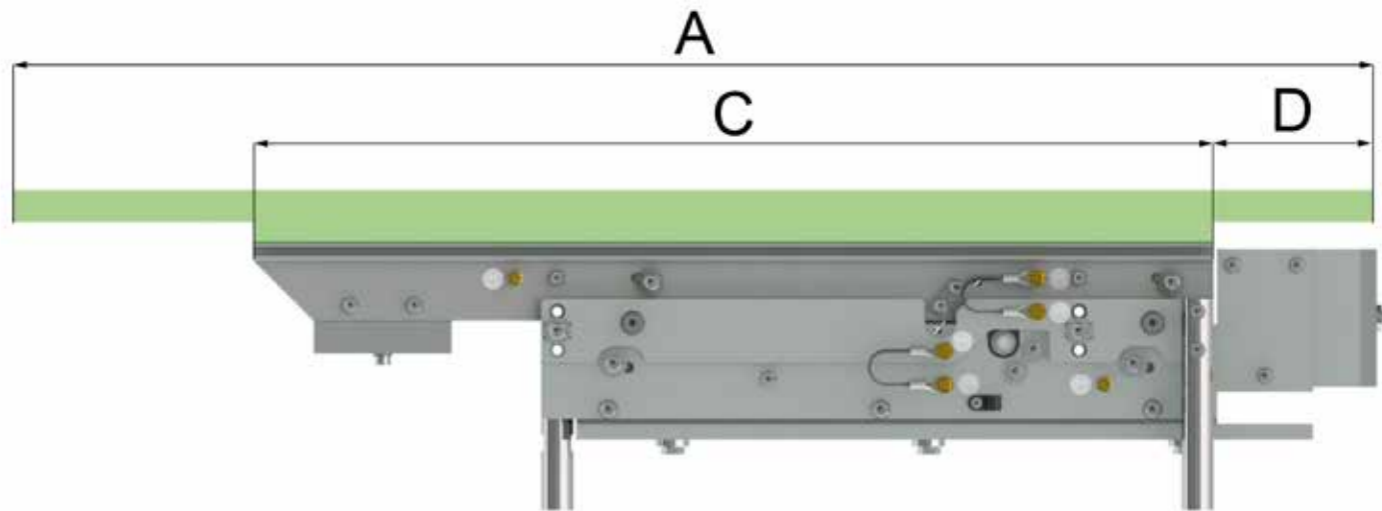

Typical application: SLA 400-400 with linear sorting device in combination with an STS nano step feeder



Type	SLA 175-250	SLA 400-400	SLA 400-600	SLA 400-800	SLA 400-1000
Dimensions LxWxH (mm)	305x70x97	511x102x168	711x102x168	911x102x168	1111x102x168
A = maximum rail length (mm)	375	650	850	1050	1250
C = length of vibratory unit (mm)	250	400	600	800	1000
D = max. rail overhang (entry end) (mm)	25	50	50	50	50
E = width of vibratory unit (s / b) (mm)	37 / 55	66 / 84	66 / 84	66 / 84	66 / 84
Weight of linear feeder (kg)	2.3	11	14	18.5	22.5
Max. weight of vibratory units, linear rail and fastening components (kg)	1.0 - 1.7	4 - 5	5 - 6.5	6 - 8	8 - 10
Max. weight of all parts lying on the rail (kg)	0.5	1	1	1	1
Current input (mA)	70	600	600	600	600
Vibrating frequency (Hz)	100	100	100	100	100
Connecting cable length (m)	1.5	1.5	1.5	1.5	1.5

# Linear feeder series PARU Mini



### Infos

- In their standard version, linear feeders of the PARU Mini type are equipped with 230V / 50Hz magnets.
- Also available with : 110V 60Hz
- Protection rating IP 54
- CE and CSA/UL

### Description

Linear feeders of the PARU Mini family are available in two sizes: PARU Mini XS and PARU Mini S. They are great for parts with high-precision guides at the transition to the escapement or the vibratory feeder (bowl feeder). Due to the balancing principle, where the useful mass moves in the opposite direction of the exciter mass, the vibratory forces of this linear feeder are essentially cancelled out in the baseplate.

The PARU Mini series is fully digitized. Each conventional process step is handled with a few clicks in the digital world. Drives can be digitally tuned and simulated with the DigitalMotion software. This enables users to balance their linear drive, to adjust the natural frequency, determine the throw angle and adjust the spring leaves. It also enables them to tune the drive to their own feeding system before they even receive it.

Access to this cloud-based service is via web browser, with the simulation taking place in real time. Vibrating forces occurring in the drive unit are compensated to prevent transferring vibrations into the substructure. Also, this prevents mutual interference between multiple combined units. There must absolutely be no interference with other units and processes. Even in their immediate vicinity, highest precision must be guaranteed at the interfaces. Transitions must not be misaligned during maintenance work, therefore they should be fixed in position with an adjustable locating device.

Typical application: PARU-Mini XS with orienting device

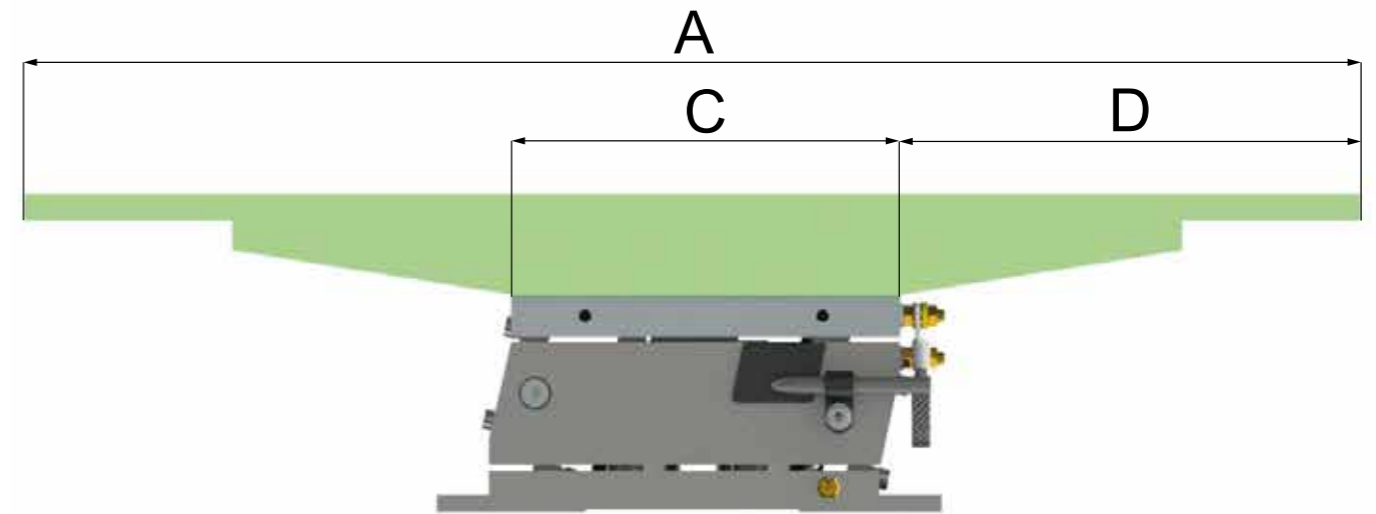

Type	PARU Mini XS	PARU Mini S
Dimensions LxWxH (mm)	170x55x73	200x60x80
A = maximum rail length (mm)	300	500
C = length of vibratory unit (mm)	131	154
D = max. rail overhang (entry end) (mm)	50	50
E = width of vibratory unit (s / b) (mm)	36	42
Weight of linear feeder (kg)	1.8	3
Max. weight of vibratory units, linear rail and fastening components (kg)	0.9	1.4
Max. weight of all parts lying on the rail (kg)	0.2	0.3
Current input (mA)	70	80
Vibrating frequency (Hz)	100	100
Connecting cable length (m)	1.5	1.5

# Linear feeder series SLS



### Infos

- In their standard version, linear feeders of the SLS type are outfitted with 230V / 50Hz magnets.
- Also available with : 115V 60Hz
- Protection rating IP 54
- CE and CSA/UL

### Description

These linear feeders are great for handling parts that require with high-precision guides at the transition from the singulation station to the outlet of the feeder bowl. Due to the balancing principle, the vibratory forces of this linear feeder are essentially cancelled out in the baseplate.

Due to the compensation of the vibrating forces in the drive unit, no vibrations are transferred to the substructure. Mutual interference between multiple combined unit, as well as interferences with other units and processes, even in the immediate vicinity, are avoided. Highest precision at the interfaces is ensured. Transitions must not be misaligned during maintenance work, therefore they should be fixed in position with an adjustable locating device.



Typical application: Feeding system with SLS 250 for pins



Type	SLS 250	SLS 400	SLS 600	SLS 800
Dimensions LxWxH (mm)	90x36x49	140x36x79.7	200x50x111.7	300x60x139.7
Maximum rail length (mm)	250	400	600	800
Width of vibratory unit (mm)	17	17	24	29
Weight of linear feeder (kg)	0.7	1	2	7
Max. weight of vibratory units, linear rail and fastening components (kg)	0.3	0.65	1.8	3.0
Max. weight of all parts lying on the rail (kg)	1.2	1.9	4.6	12
Current input (mA)	45	70	115	275
Vibrating frequency (Hz)	100	100	100	100

When placing an order, please specify the type of linear feeder used.

## Accessories for linear feeders of the SLL series

### Substructure ULJ-2 for SLL 400-Set

Comprising:

- Mounting plate for SLL 400-400, SLL 400-600, SLL 400-800, SLL 400-1000
- Width extender plates for SLL 400
- 2 x stand columns
- 2 x RNA mounting feet
- also available for SLL 800/804



### Mounting plate ULJ-2 for SLL 400-Set

- for sizes SLL 400-400, SLL 400-600, SLL 400-800, SLL 400-1000
- also available for SLL 800/804



### Width extender UTL-3 for SLL 400

Comprising:

- 2 x fixing plates
- 4 x rubber-metal isolators



### Width extender for SLL 800 + 804

Comprising:

- 2 x fixing plates
- 4 x rubber-metal isolators



### Stand foot ULJ-2

Comprising:

- 1 x cast aluminium foot
- 1 x clamping column



### Lateral vibration limiters SLJ for SLL

Comprising:

- 3 x aluminium brackets, anodized
- 3 x pins, POM / S-black



### Mount for EGF photoelectric cells, for mounting on ULJ stands

Comprising:

- 1 x holder for EGF sensor
- 1 x headpiece
- 1 x column
- 1 x mounting plate



### Shipping braces for SRC-N and SLL drives



### Light barrier



# FlexCubes

FlexCube is the ideal feeding system when high flexibility in production is required. FlexCube vibratory platforms are usually operated together with an image processing system and a robot for the feeding of parts having different geometries. Thanks to our patented 3-axis system, even sensitive parts can be fed safely and reliably.

The parts are evenly distributed on the surface of the feeder. If required, they can also be aligned in all directions using textured baseplates and smart vibratory motions. Whole families of parts can be singulated and supplied by such a feeding system, making it usable for future tasks too.

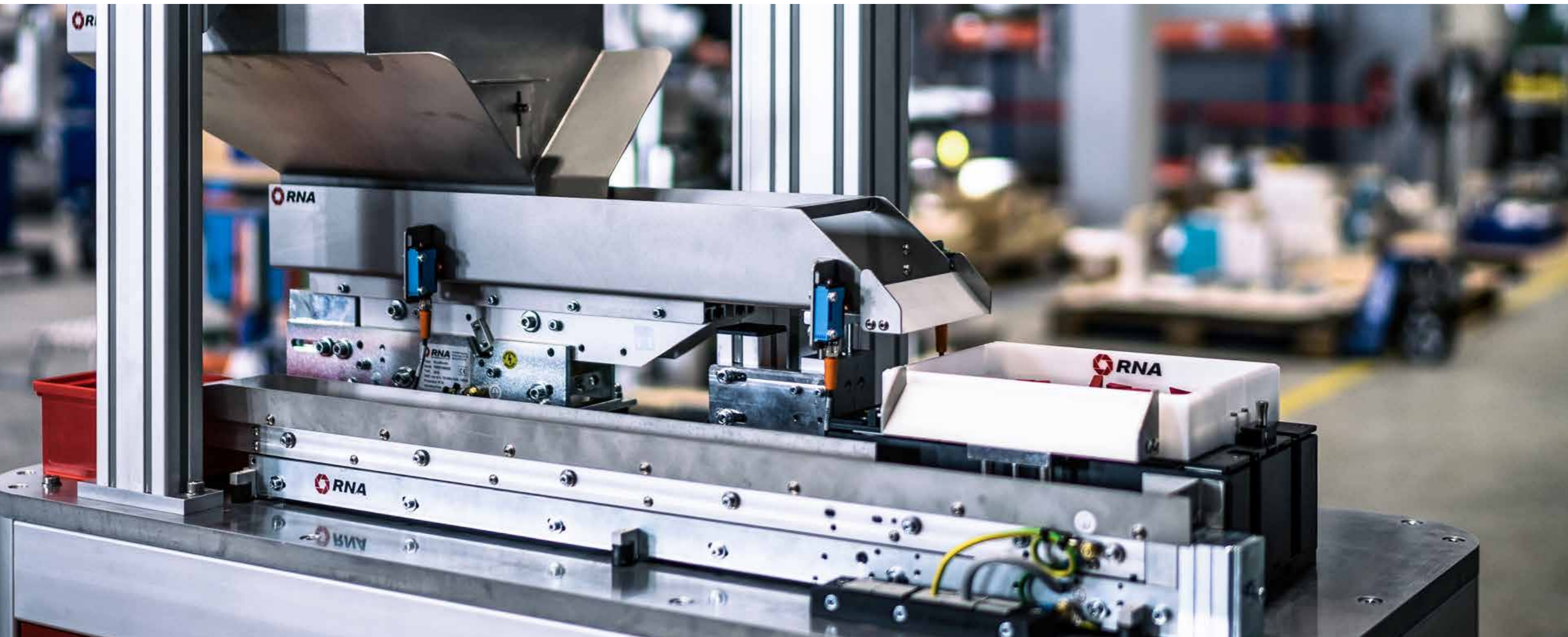

# FlexCube 50, 80, 240, 380, 530



### Infos

- **Compatible with all parts geometries**
- **Minimum change-over times**
- **Extremely gentle part handling**
- **Free movement of the parts**
- **Prevents transmission of vibrations**
- **Systematic part orientation**
- **Easy configuration**

### Description

RNA's components for vibratory platforms provide you with a complete range of products to compose your flexible feeding systems. From specially designed hoppers to quick dumps and plastic plates tailored to your specific requirements, RNA offers the optimum solution to your needs.

Our intelligent vibratory systems offer possibilities for controlled part movements in all directions, as well as for precise metering and exact attitude detection and presentation of parts. The hoppers of our BVL-P series have been developed to promote uniform parts feeding. Combined with sensors and a shutoff gate, they also prevent overflowing of the vibratory platform. The quick dump system enables you to run all parts out of the platform in a swift and efficient manner. Ejected parts are returned via an SLL 175-800 linear feeder which is also a recent addition to our product line-up.

At your request, RNA can also offer a complete line-up of modular components for the most diverse tasks.

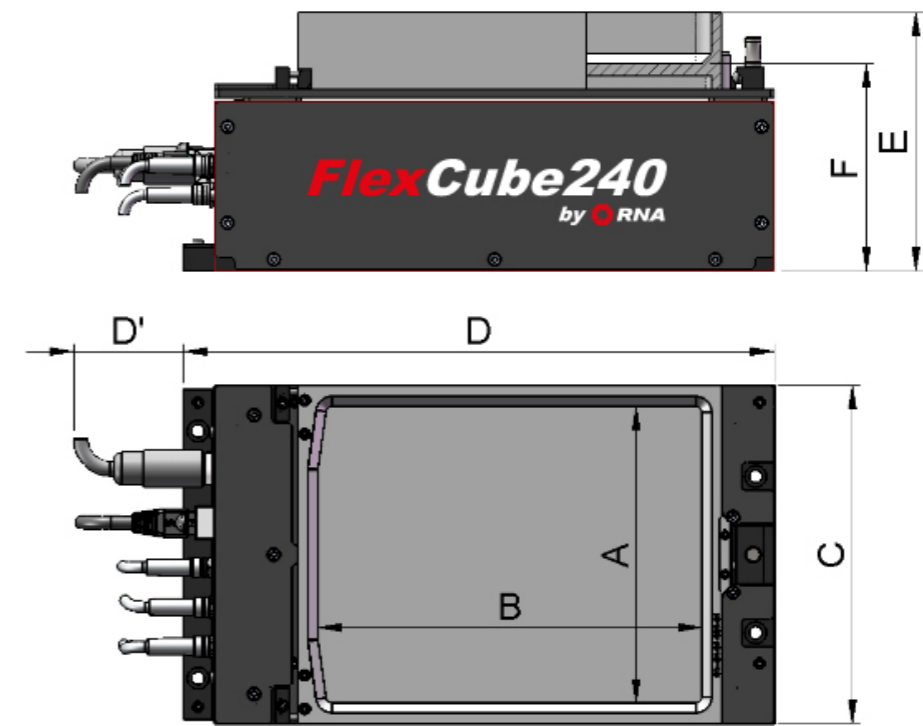

Be informed that we offer a comprehensive range of accessories for FlexCubes. As the accessories are highly specific to the tasks at hand and the parts to be handled, we are here to put them together for your application,

Typical application: FlexCube 240 for plastic parts



Type	FlexCube 50	FlexCube 80	FlexCube 240	FlexCube 380	FlexCube 530
Typical part dimensions (mm)	< 0.1 - 5	3 - 15	5 - 40	15 - 60	30 - 150
Available vibratory plate surface area (mm)	A = 34 B = 45	A = 52 B = 65	A = 150 B = 195	A = 254 B = 325	A = 371 B = 427
Overall dimensions (mm) (mounting surface area)	C = 46 D = 293	C = 65 D = 320	C = 171 D = 300	C = 257 D = 499	C = 372 D = 600
Total height (mm)	E = 140	E = 140	E = 132	E = 307	E = 320
Pick-up height (mm)	F = 110	F = 111	F = 105	F = 245	F = 360
Power supply	24V/6A	24V/6A	24V/8A	24V/20A	24V/20A

## RNA hopper systems for precise filling of / feeding to downstream equipment

The use of hoppers offers multiple advantages to users:

**Metered filling:** Metered filling of the feeder bowl prevents variations in running speed due to fluctuating filling levels.

**Gentle part handling:** There are only as many parts present in the process as are needed to meet the required performance data.

**Availability:** The availability of the feeding system increases as there is less entanglement of the parts with each other, and less part jamming in the orienting tools.

**Autonomy:** The autonomy of a sorting system can be increased considerably by including a hopper.

**Ergonomics:** The ergonomics of filling the equipment can be greatly enhanced by adding hoppers.

In the following pages we present our standardised systems - available from stock - but also custom systems, as well as a summary overview of the various possibilities for parts storage and filling.

We are here to assist you in rating and dimensioning your hoppers and to prepare a concept, including a quotation.



# Vibratory hopper series BVL



### Infos

- Available from stock
- With the exception of size BVL 3, all hoppers of the BVL hopper series have a bolted-on outlet chute. The slope of this chute is adjustable.
- Prepared for Plug & Play in combination with RNA control unit
- Optionally available with coating
- Available for all mains voltages

### Description

Vibratory hoppers of the BVL series are designed for metered filling of downstream feeder bowls.

The hopper tray is manufactured from 1.4301 grade stainless steel and glass-bead blasted.

For optimal transmission of the vibrations, we place particular emphasis on the stiffness of the hopper trays.

The adjustable discharge chute serves to guide the parts to the desired place.

Vibratory hoppers of the BVL series are factory-tuned to the permissible useful weight, so that the bulk products (parts handled) are pre-singulated with increasing speed towards the exit. A fine-tuning can be performed at any time by the user.

BVL series hoppers are available from stock.



Typical application: Feeding system with BVL-5 for metered filling of the feeder bowl



Type	BVL 3	BVL 5	BVL 15	BVL 25	BVL 50	BVL 70	BVL 100
Filling volume (l)	3.5	7	15	25	50	70	100
Filling weight (kg)	15	15	20	25	50	50	50
Drive	SLL 400-400	SLL 400-400	SLL 400-600	SLL 400-800	SLL 804-800	SLL 804-1000	SL 804-1000
Rated voltage	200V / 50Hz	200V / 50Hz	200V / 50Hz	200V / 50Hz	200V / 50Hz	200V / 50Hz	200V / 50Hz
Current input approx.	0.6 A	0.6 A	0.6 A	0.6 A	1.26 A	1.26 A	1.26 A
Vibrating frequency	100 Hz	100 Hz	100 Hz	100 Hz	50 Hz	50 Hz	50 Hz
Protection rating	IP54	IP54	IP54	IP54	IP54	IP54	IP54
Length of connecting cable (mm)	1,800	1,800	1,800	1,800	1,800	1,800	1,800
Dimensions L x W x H	504 x 124 x 229	718 x 237 x 270	946 x 309 x 313	1145 x 309 x 313	1316 x 380 x 428	1453 x 384 x 482	1527 x 431 x 510

Standard voltage 200 V / 50 Hz. Also available with special voltage of 110 V and frequencies of 50 Hz or 60 Hz.

All hopper trays (BVL 3 - BVL 5 - BVL 15 - BVL 25 - BVL 50 - BVL 70 - BVL 100) available in sizes from 3 to 100 litres.

# Mini-vibratory hopper series BVL-M



- Infos**
- Available from stock
  - With the exception of size BVL 3, all hoppers of the BVL hopper series have a bolted-on outlet chute. The slope of this chute is adjustable.
  - Prepared for Plug & Play in combination with RNA control unit
  - Optionally available with coating
  - Available for all mains voltages

**Description**

Vibratory hoppers of the BVL-M series have the same design as BVL series hoppers. They have been developed for applications requiring small filling volumes, and are the ideal complement for small feeder bowls or vibration platforms.

Vibratory hoppers of the BVL are factory-tuned to the permissible useful weight, so that the bulk product (parts handled) are pre-singulated with increasing speed towards the exit. A fine-tuning can be performed at any time by the user.



Typical application: Two 2 BVL-3M with static hopper for metered filling of a vibratory platform



Type	BVL 0.8-M	BVL 1-M	BVL 2-M	BVL 3-M
Filling volume (l)	0.8	1	2	3
Filling weight (kg)	3	3	15	15
Drive	SLL 175-250B	SLL175-250B	SLL 400-270S	SLL 400-400S
Rated voltage	200V / 50Hz	200V / 50Hz	200V / 50Hz	200V / 50Hz
Current input approx.	0.07A	0.07 A	0.6 A	0.6 A
Vibrating frequency	100 Hz	100 Hz	100Hz	100 Hz
Protection rating	IP 54	IP54	IP54	IP54
Length of connecting cable (mm)	1,800	1,800	1,800	1,800
Dimensions L x W x H	419 x 86 x 130	443 x 86 x 130	507 x 160 x 211	715 x 160 x 234

# Vibratory hopper series BVL-S and BVL-SE



### Infos

- Available from stock
- With adjustable discharge chute
- Prepared for Plug & Play in combination with RNA control unit
- With quick dump gate
- Optionally available with coating
- Available for all mains voltages

### Description

Vibratory hoppers of the BVL-S series are an upgrade of the BVL series. They have the same characteristics. In hoppers of the BVL-S series, the rear of the hopper tray is sloped. This offers the advantage that the hopper tray extends over the add-on weights of the linear feeder, and also the possibility to integrate a quick dump gate.

BVL- S series hoppers are available from stock.

Typical application: BVL-25 SE for metered feeding of pins to an incline conveyor



Type	BVL 3S BVL 3S-SE	BVL5 S BVL5 S-SE	BVL 10S BVL 10S-SE	BVL 15S BVL 15S-SE	BVL 25S BVL 25S-SE	BVL50 S BVL50 S-SE
Filling volume (l)	3.5	7	10	15	25	50
Filling weight (kg)	10	10	10	20	25	50
Drive	SLL 400-270	SLL 400-400	SLL 400-600	SLL 400-600	SLL 400-800	SLL 804-800
Rated voltage	200V / 50Hz	200V / 50Hz	200V / 50Hz	200V / 50Hz	200V / 50Hz	200V / 50Hz
Current input approx.	0.6 A	0.6 A	0.6 A	0.6 A	0.6 A	1.26 A
Vibrating frequency	100 Hz	100 Hz	100 Hz	100 Hz	100 Hz	50 Hz
Protection rating	IP54	IP54	IP54	IP54	IP54	IP54
Length of connecting cable (mm)	1,800	1,800	1,800	1,800	1,800	1,800
Dimensions L x W x H	572 x 210 x 261	782 x 250 x 275	1002 x 252 x 305	1017 x 309 x 315	1216 x 310 x 315	1404 x 380 x 430

\*Standard voltage 200V / 50 Hz. Also available with special voltage of 110 V and frequencies of 50 Hz or 60 Hz.

# Heavy-duty vibratory hopper series BV



## Infos

- **High loading weights**
- **Available from stock**
- **With fixed discharge chute**
- **Prepared for Plug & Play in combination with RNA control unit**
- **Optionally available with coating**
- **Available for all mains voltages**

## Description

Vibratory hoppers of the BV50 – BV 200 series have been specially designed for storing and metered feeding of large filling volumes with high weights. As for all vibratory hoppers supplied by RNA, the trays of BV series hoppers are manufactured from 1.4301 grade stainless steel. The special design of the trays combined with the linear drives and controllers enables these hoppers to handle weights up to 180 kg.

Vibratory hoppers of the BV series are not only used in high throughput applications with the associated requirement for high filling volumes, but also to feed larger and/or heavy parts.



Typical application: Vibratory hopper BV 200 shown as single component



Type	BV 50	BV 100	BV 150	BV 200
Filling volume (l)	50	100	150	200
Filling weight (kg)	150*	150*	180*	180*
Drive	SLF 1000-1000S	SLF 1000-1000S	SLF 1000-1000S	SLF 1000-1000S
Rated voltage	200V / 50Hz	200V / 50Hz	200V / 50Hz	200V / 50Hz
Current input approx.	2.5 A	2.5 A	2.5 A	2.5 A
Vibrating frequency	50 Hz	50 Hz	50 Hz	50 Hz
Protection rating	IP54	IP54	IP54	IP54
Length of connecting cable (mm)	1,800	1,800	1,800	1,800
L x W x H (mm)	1588 x 609 x 410	1588 x 716 x 505	1594 x 716 x 571	1592 x 716 x 668

\*The maximum filling weight depends on the condition of the parts to be handled. Applies only in connection with SCF 3000 and vibration amplitude sensor.

# Vibratory hopper series BVL-P

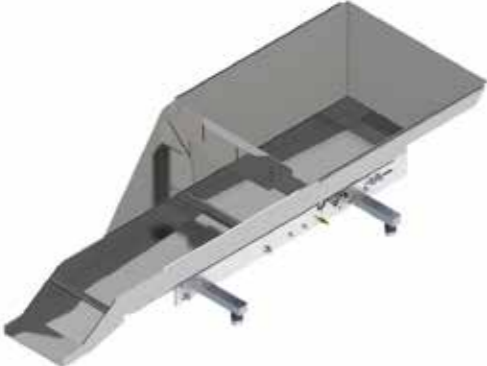

- Infos**
- **A perfect match for vibratory platforms**
  - **Available from stock**
  - **With fixed discharge chute**
  - **Prepared for Plug & Play in combination with RNA controller**
  - **Optionally available with coating**
  - **Available for all mains voltages**

**Description**

Vibratory hoppers of the BVL-P series have been conceived for finely metered feeding of bulk products. The hopper tray is designed with a defined filling area from where the parts are transferred to the downstream process by way of a stepped bottom. This bottom permits the feeding of parts lying flat in a single layer. These vibratory hoppers are the equipment of choice in applications relying on vibratory platforms.

Typical application: FlexCube 380 with upstream BVL 15-P

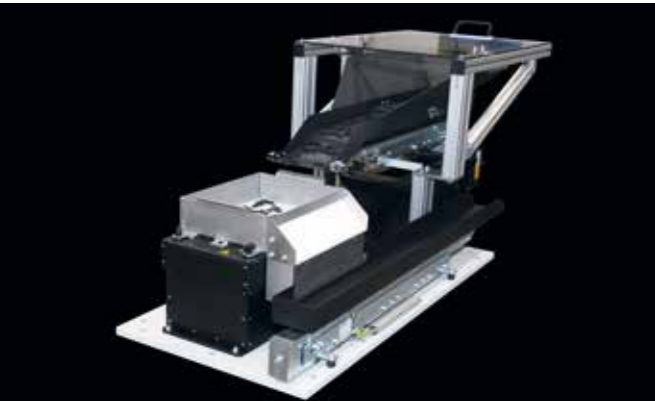

Type	BVL 7	BVL 12 - P	BVL 15 - P	BVL 20 - P
Filling volume (l)	3	10	15	20
Filling weight (kg)	15	20	15	20
Drive	SLL 400-400S	SLL 400-600B	SLL 400-800B	SLL 400-800B
Rated voltage	200V / 50Hz	200V / 50Hz	200V / 50Hz	200V / 50Hz
Current input approx.	0.6 A	0.6 A	0.6 A	0.6 A
Vibrating frequency	100 Hz	100 Hz	100 Hz	100 Hz
Protection rating	IP54	IP54	IP54	IP54
Length of connecting cable (mm)	1,800	1,800	1,800	1,800
Dimensions: L x W x H	715 x 160 x 234	919 x 299 x 237	1127 x 429 x 340	1127 x 440 x 340

# Belt-type hopper series BUW



### Infos

- **Compact design**
- **Also suited for FDA applications**
- **With fixed discharge chute**
- **Optionally with quick dump**
- **Optional covers**
- **Prepared for Plug & Play in combination with RNA controller**
- **Available for all mains voltages**

### Description

BU-W series belt-type hoppers are intended for storage of parts and increase the autonomy of the feeding system they supply. They are conceived for horizontal filling of downstream systems.

The basis of these belt-type hoppers is RNA's proven belt feeder FP120. A distinct characteristic of BU-W belt-type hoppers is their compact direct drive system and their top-mounted components from stainless steel brushed on both sides.

BU-W belt-type hoppers are available from stock.

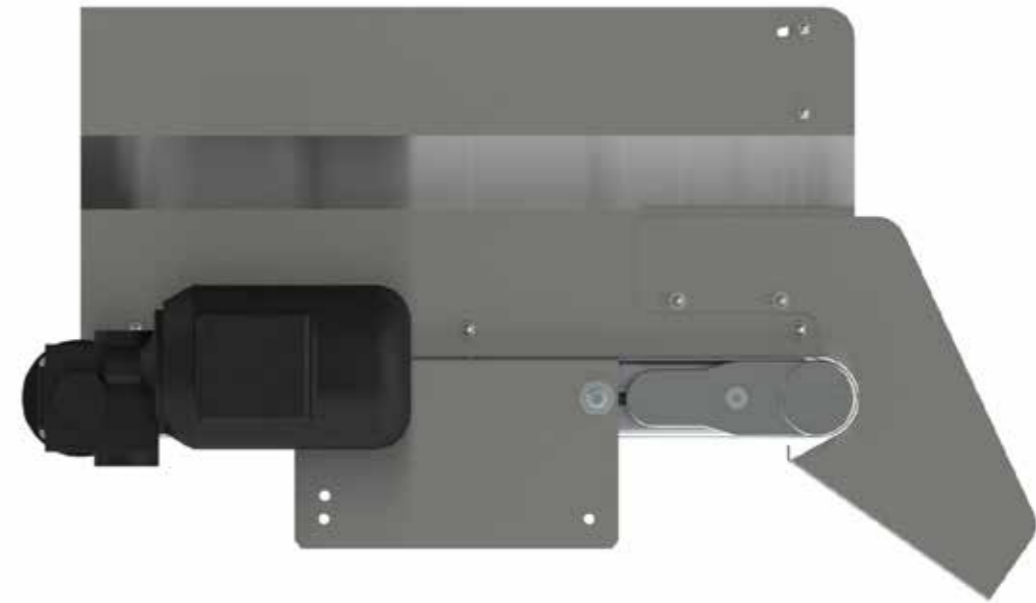

Typical application: Feeding system with BUW-25 for metered filling



Type	BU-W 5	BU-W 15	BU-W 25	BU-W 50	BU-W 100	BU-W 200
Filling volume (l)	5	15	25	50	100	200
Filling weight (kg)	15	50	70	80	100	100
Belt speed (m/min)	1 or 2					
Rated voltage (V)	230/400 or 230					
Current input (A)	0.37 or 0.64					
Motor rating (W)	90					
Motor position	Standard motor position 6 (on right when viewed in feeding direction) / alternatively motor position 1 (on left when viewed in feeding direction)					
Total length (mm)	590	590	640	940	1140	1140
Width excluding motor (mm)	125	250	280	380	430	430
Dimensions: L x W x H	615 x 125 x 105	615 x 250 x 205	665 x 280 x 240	965 x 380 x 240	1165 x 430 x 290	1165 x 430 x 510

# RNA Group



**Rhein-Nadel Automation GmbH**  
Reichsweg 19-23  
D-52068 Aachen  
Phone +49 241-5109-0  
vertrieb@rna.de  
www.rna.de  
www.designforfeeding.com



**RNA Digital Solutions GmbH**  
Postal address  
Reichsweg 19-23  
D-52068 Aachen  
Office address  
Briener Straße 45 a-d  
D-80333 München  
Phone +49 1515-99 28 255  
kontakt@madigital.de  
www.madigital.de  
www.designforfeeding.com



**PSA Zuführtechnik GmbH**  
Steinackerstraße 7  
D-74549 Wolpertshausen  
Phone +49 7904-94336-0  
E-mail info@psa-zt.de  
www.psa-zt.de



**Feeding Systems Amberg GmbH**  
Kastnerstraße 3  
D-92224 Amberg  
Phone +49 9621-917096-0  
info@fsa-amberg.de  
www.fsa-amberg.com



**Metalaix GmbH**  
Philipsstr. 8 (Gebäude VAVE)  
D-52068 Aachen  
Tel +49 241-942607-0  
kontakt@metalaix.de  
www.metalaix.de



**HSH Handling Systems AG**  
Wangenstraße 96  
3360 Herzogenbuchsee  
Switzerland  
Phone +41 62-95610-00  
info@handling-systems.ch  
www.handling-systems.ch



**RNA Vibrant S.A.**  
C/ Vallespir 22  
08970 Sant Joan Despi (Barcelona)  
Spain  
Phone +34 93-377-7300  
info@vibrant-rna.com  
www.vibrant-rna.com



**RNA Automation Ltd.**  
Unit C Castle Bromwich Business Park  
Tameside Drive Birmingham B35 7AG  
Great Britain  
Phone +44 121-749-2566  
sales@maautomation.com  
www.maautomation.com

Further production sites of Rhein-Nadel Automation GmbH

Lüdenscheid site  
Nottebohmstraße 57  
D-58511 Lüdenscheid  
Phone +49 2351-41744  
werk.luedenscheid@rna.de

Ergolding site  
Ahornstraße 122  
D-84030 Ergolding  
Phone +49 871-72812  
werk.ergolding@rna.de

Remchingen site  
Im Hölzlerle 3  
D-75196 Remchingen-Wilferdingen  
Tel +49 7232-7355-558  
werk.remchingen@RNA.de