

## Operating and Assembly Instruction

### Vibratory feeder

### ROTU M

# Table of contents

1.	Safety Instructions.....	4
1.1.	General information .....	4
1.2.	Symbols and notes .....	4
1.3.	Intended use .....	4
2.	Product Description.....	5
2.1.	General information .....	5
2.2.	Technical data.....	5
2.3.	Description of functions.....	6
3.	Mounting Instructions .....	8
3.1.	Transportation.....	8
3.2.	Assembly .....	9
3.3.	Bringing into service.....	9
4.	Operating Instructions .....	10
4.1.	Operation .....	10
4.2.	Tooling change .....	11
4.3.	Maintenance intervals and time limits .....	11
5.	Storage, Dismantling, Disposal .....	12
6.	Troubleshooting .....	12
7.	Spare and wear parts.....	12

## Declaration of Incorporation

Im Sinne der Maschinenrichtlinie 2006/42/EG  
according to Machinery Directive 2006/42/EC

We,  
Company

**Rhein-Nadel Automation GmbH**  
Reichsweg 19-23  
52068 Aachen  
Germany

herewith declare under our sole responsibility that with regard to the following product:

Machine designation: (function)	Vibratory Feeders
Type designation:	ROTU M (...)
Year:	2019
Serial number:	10900000 0001 – 25000000 0001

all relevant essential safety and health requirements of Directive 2006/42/EC have been fulfilled up to the battery limits.

The product to which this declaration refers is furthermore in conformity with following directives and standards or other regulations:

2006/42/EC	Machinery		
2014/35/EU	Low Voltage		
2014/30/EU	Electromagnetic Compatibility		
EN 614-1	2006+A1:2009	EN ISO 13857	2008
EN 619	2002+A1:2010	EN ISO 14120	2015
EN 620	2002+A1:2010	EN 60204-1	2006
EN ISO 12100		2010	

The relevant technical documentation has been compiled in accordance with Annex VII B of the Machinery Directive and on request, such documentation will be transmitted to the competent authorities in hard copy.

Nico Altmeyer, Rhein-Nadel Automation GmbH, Reichsweg 19-23, 52068 Aachen

**(Name and address of person authorised to compile the relevant technical documentation)**

**Notice:** This machine must not be put into service until the complete system into which it will be incorporated has been declared to be in conformance with the provisions of the Directive.

**Signatory information**

Name: Grevenstein

Given name: Jack

Function: Managing Director

Germany

Aachen,

\_\_\_\_\_  
Place and date

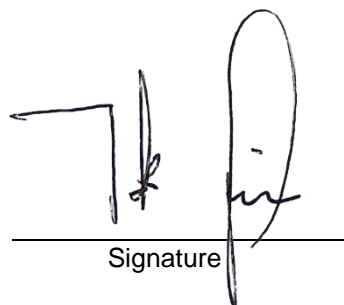

\_\_\_\_\_  
Signature

# 1. Safety Instructions

## 1.1. General information

These operating and assembly instructions contain all the necessary information for the safe installation and operation of the ROTU M. This document, especially the safety instructions, must be observed by all persons working on or with the ROTU. In addition to the information in these operating and assembly instructions, the accident prevention rules and regulations applicable at the place of use must also be observed.

We recommend to keep the operating and assembly instructions at the place of operation of the ROTU M at all times. The risk assessment procedure used is taken from DIN EN ISO 12100:2011.

## 1.2. Symbols and notes

In these operating and assembly instructions there are four different signal words, three of them with a symbol. In order of decreasing importance, these are as follows:



### **Danger!**

This symbol indicates an imminent danger to the life and health of persons. Failure to observe these instructions will result in severe adverse health effects, including life-threatening injuries.



### **Attention!**

The symbol indicates possible damage to property and/or the environment.



### **Note!**

This symbol indicates important facts and particularly useful information.

## 1.3. Intended use

The intended use of ROTU M is the drive of toolings of Rhein-Nadel Automation GmbH in automatic continuous operation and the interaction with a downstream process, which picks up the conveyed goods. The toolings are sorting devices adapted to the ROTU and are used for the orderly, individual feeding of bulk material for automatic acceptance by a downstream process (e.g. handling device). Any other use or structural modification of the ROTU M is considered improper use. Intended use also includes observance of these operating and assembly instructions.

ROTU M may only be used with the appropriate tooling from Rhein-Nadel Automation GmbH. Any other use is considered "not as intended". No changes or modifications may be made to the ROTU M without prior consultation with and approval by the specialist personnel of Rhein-Nadel Automation GmbH.

The area of application of the ROTU M within the scope of its intended use is in covered and enclosed industrial production and assembly facilities ("industrial area").



### **ROTU may not be used:**

1. outdoors
2. in wet or hazardous areas
3. under daylight
4. in areas with highly flammable media
5. in aggressive environments (e.g. saline atmosphere)
6. in production plants requiring clean room conditions
7. in private households

The limits of the temperature range of ROTU M are given by the installed electromagnets. The ambient temperature should not exceed 40°C and its average value over a period of 24 hours should not exceed 35°C. The lower limit for the ambient temperature is -5°C. The altitude of the place of use shall not exceed 2000 m above sea level. The relative humidity of the ambient air should not exceed 50% at 40°C. At lower temperatures, higher humidity may be allowed, e.g. 90% at 20°C. The ambient air should not be significantly contaminated by dust, smoke, aggressive gases and vapors. Avoid direct sunlight or high UV radiation, as this can lead to embrittlement of some plastics that may be used in tooling and can make it difficult to read displays.

The following groups of persons ("users") are authorized to handle ROTU M:

1. instructed person: The instructed person has demonstrably been instructed in an instruction by the operator about the tasks assigned to him on the ROTU M and possible dangers in case of improper behavior on the ROTU M. Instruction

is the basic prerequisite for working on the ROTU M. Reading the technical documentation of the ROTU M is part of the instruction.

2. qualified personnel: Due to their technical training, knowledge and experience as well as their knowledge of the relevant standards and regulations, qualified personnel are able to carry out the assigned work on the ROTU M and to independently recognize possible dangers when handling the ROTU M and to avoid hazards. A qualified electrician who, due to his professional training, knowledge and experience as well as knowledge of the relevant standards and regulations, is able to carry out work on the electrical components of the ROTU M and to recognize and avoid possible dangers independently. The qualified personnel also includes the electrician.

3. Certain work, such as the replacement of electromagnets, leaf springs or other components of the ROTU M, may only be carried out by qualified personnel of Rhein-Nadel Automation GmbH or after prior consultation with qualified personnel of Rhein-Nadel Automation GmbH. To carry out this work, please contact our customer service: [vertrieb@rna.de](mailto:vertrieb@rna.de)

## 2. Product Description

### 2.1. General information

ROTU M is a standardized platform for the correct, individual supply of bulk materials in automated production or assembly. For this purpose, ROTU M is equipped with a material-specific tooling and integrated into the operator's production or assembly plant either alone or as part of a feed system. ROTU M is thus a partly completed machine in the sense of the EC Machinery Directive 2006/42/EC.

With new toolings from Rhein-Nadel Automation GmbH, ROTU M can be converted at any time to feed new materials. The toolings are supplied by Rhein-Nadel Automation GmbH with information on the optimum amplitude, frequency, filling quantity and, if necessary, compressed air settings. No adaptation of the drive is necessary. ROTU M thus offers flexible feeding of materials with high conveying capacities and short changeover times.

#### Note!



ROTU M is a precision machine. The functionality of the tooling depends on the accuracy of the topology to the tenth of a millimeter. The settings on the control unit, the filling quantity, the level of the conveyed materials and the quality of the screw connections must also correspond to the conditions for target-oriented functionality.

### 2.2. Technical data

ROTU M is a standardized platform for the storage-oriented, individual supply of bulk materials in automated production

dimensions LxBxH [mm]	515 x 484 x 440
Mass without tooling [kg]	104,2
Supply voltage [V]	0...230
power [VA]	1128
Vibration frequency [Hz]	50
Running direction	Clockwise or counterclockwise rotation
Protection class IP	54
Operating temperature range [°C]	-5...+35
Compressed air supply [bar]	6
Filling volume in ROTU	According to Tooling-specification
Noise emission: Continuous sound pressure level (without conveyed material)	< 70 dB (A)

#### Note!



The noise emission depends on the material to be conveyed and can therefore only be determined on site under real conditions. If the sound pressure level exceeds the permissible level, suitable noise protection measures must be taken.

Figure 1 shows the dimensions of the ROTU M.

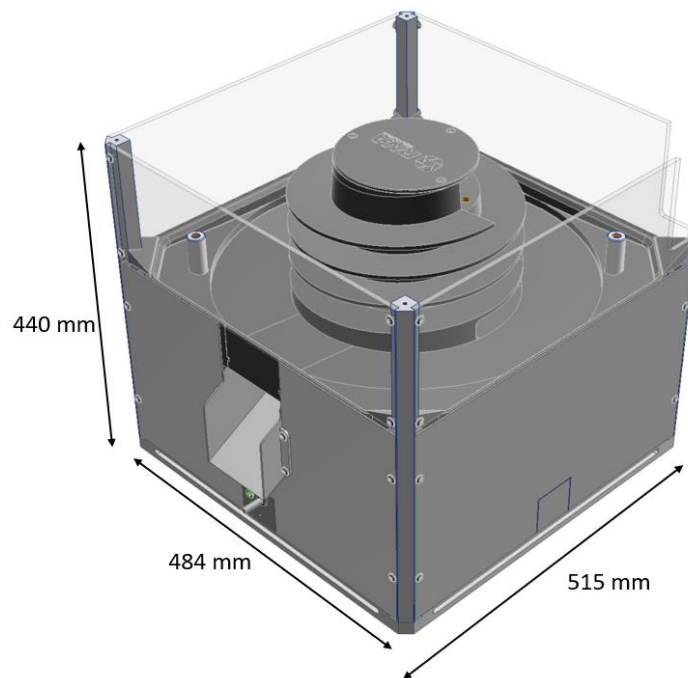

Figure 1: Dimensions of the ROTU M

This results in the following spatial limits for a ROTU M:

- 1) Required floor space ROTU M: 550mm x 550mm x 500mm (length x width x height).
- 2) Minimum load capacity of the footprint for ROTU M: 150 kg per square meter
- 3) Recommended functional area (for accessibility quick emptying, tooling change, maintenance etc.): 550mm x 550mm
- 4) Recommended space for ergonomic assembly: 1 m<sup>2</sup>

As a rule, the user only has to observe the screw tightening torque for the tooling fastening (ISO 4762, M8x30, washer ISO 125, form B). For reasons of completeness as well as for a possible maintenance case, the screw tightening torques of the remaining screw connections of the ROTU M (all screws strength class 12.9) are given below in Table 2:

ISO 4762 M12 screws for leaf spring [Nm]	70
ISO 4762 M12 Screws in strut dome top [Nm]	100
ISO 4762 M10 Screws in EM anchor holder [Nm]	50
ISO 7379 M12 Fitting bolts for struts, EM holder [Nm]	100
ISO 4762 M10 Screws for the rubber feet [Nm]	15
ISO 4762 M6 screws [Nm]	14
ISO 4762 M12 screws in aluminum [Nm]	70
ISO 4762 M10 screws in aluminum [Nm]	45
ISO 4762 M8 screws in aluminum/EnSat [Nm]	25
ISO 4762 M8 screws in Ensat/inner spiral [Nm]	15
DIN 933 M8 screws for PA6-Base [Nm]	25
All M5 screws	5

### 2.3. Description of functions

ROTU M is a dual-mass oscillator. In the ROTU M, the counter mass and the effective mass are connected to each other by obliquely set leaf springs with a fixed, non-adjustable angle. Vibrating magnets excite the system. This results in an oscillating, helical movement of the working mass and the tooling. Due to this movement, the conveyed goods are accelerated in circumferential and vertical direction and thus move on the spiral-shaped, ascending conveying helix or along the tooling. ROTU M oscillates in the range of 100Hz, the amplitude in z-direction is up to 80µm, the amplitude in circumferential direction is up to 1,5mm (orientation values). ROTU M can be ordered in either left or right hand rotation.

Figure 2 shows ROTU M without tooling. The materials to be conveyed are fed into the base (1) of the ROTU for storage and then travel up the material-independent spiral (3) towards the tooling. Each tooling is fastened to the four support rods (2) by means of four M8 screws supplied. Two en-sat bushings (4) are located on the inner helix for the attachment of further, material-specific arrangement elements by means of M8 screws.

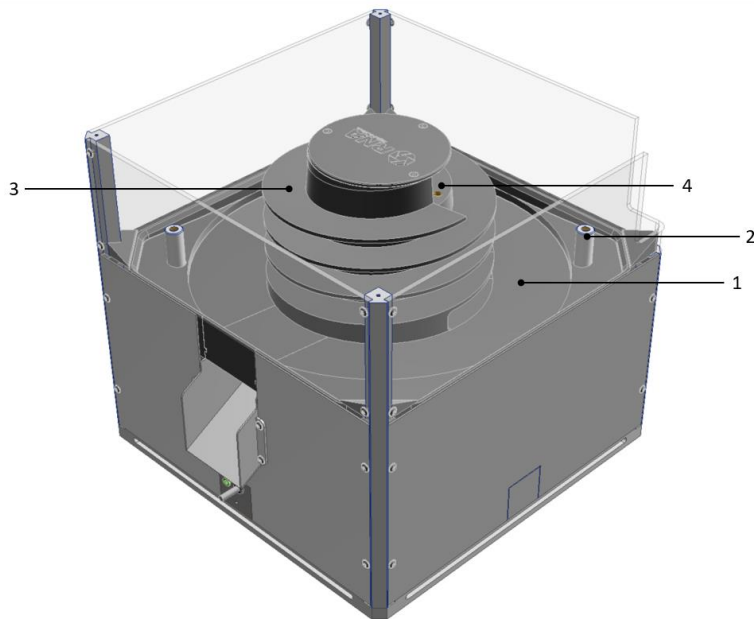

Figure 2: ROTU M without tooling

Figure 3 shows ROTU M with an exemplary tooling shown in green.

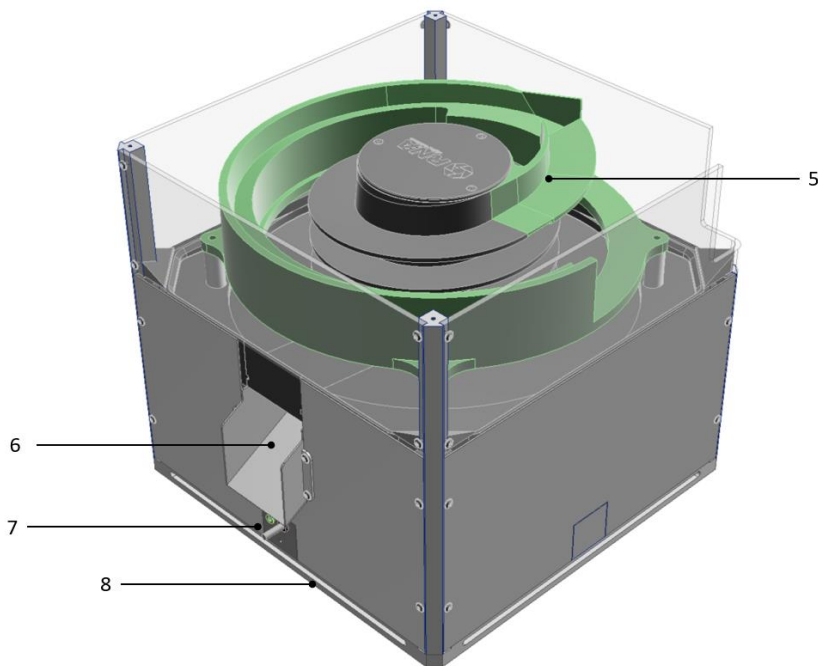

Fig. 3: ROTU M with tooling (shown in green)

The conveyed goods are oriented and aligned via the tooling (5) and the conveyed goods-specific arrangement elements. The conveyed products are placed directly into the base of the ROTU M. The ROTU M is quickly emptied via the quick-emptying pocket in the base (6). By reorienting the stainless steel housing and the substructure, the operator can choose from four possible quick discharge positions. At the same time, the quick-emptying system is used for dirt separation. The media supply (7) is located near the base plate of the ROTU M and includes an externally tolerated 6mm diameter plug-in connection (Festo QSM-M5-6-I) for compressed air as well as the line cable for the electrical supply of the vibrating solenoids. ROTU M is firmly connected to the installation site via four clamping claws by means of the grooves (8) recessed in the side of the base plate. The ROTU M housing is firmly connected to the base plate and does not move in any way.

## 3. Mounting Instructions

### 3.1. Transportation

ROTU M is packed for transport in a wooden crate suitable for the requirements and padded with polystyrene chips as damping and filling material, cf. figure 4, or delivered on a Euro pallet.



Figure 4: ROTU M in transport case with transport lug of the transport rod

To transport the feeding system, you need a forklift truck or a suitable hoist to be able to transport ROTU M to its place of use. If the wooden crate/Euro pallet is severely damaged upon delivery, please contact the carrier immediately. In order not to lose the claim for damage settlement due to formal errors, please consider the general terms and conditions of the forwarding company.

ROTU M is screwed to the bottom plate of the wooden box/Euro pallet. When unpacking and transporting the feeder system, please observe any enclosed instruction leaflets. We recommend to keep the transport box/Europallet and the packing material for a return of your ROTU M.

The scope of delivery of the ROTU M includes, unless otherwise agreed upon

1. transport box
2. transport rod with transport eye for lifting the transport box as well as the ROTU M
3. 4x clamping claws for fastening the ROTU M at the destination or fastening means as agreed with the user
4. ROTU M optionally in right-handed or left-handed version
5. operating and installation instructions
6. installation declaration
7. Tooling or tooling sets with setting recommendations, if required



#### **Attention!**

ROTU M must not be lifted or transported by the tooling. Before transport, make sure that the lifting gear used has a sufficient load capacity for the ROTU M (with too-ling and shipping box at least 150kg). During transport no persons are allowed to stay underneath the ROTU M.



## 3.2. Assembly

ROTU M is delivered completely assembled, so that you only have to unpack ROTU M and assemble it at the destination. After unpacking the ROTU M from the wooden crate/Euro pallet, you should first check the visible surfaces of the ROTU M and, if necessary, clean it to remove any contamination that may have entered the ROTU during transport. If necessary, please refer to the enclosed instructions for any adjustment and assembly work agreed individually with the customer.



### Attentio!

When placing the ROTU M on the target substructure, the temporary parking place or the target machine into which the ROTU M is to be integrated, sufficient load capacity must be ensured. The target location must be dimensioned in such a way that no vibrations of the machine can be transmitted to the ROTU M or no vibrations can be transmitted from the ROTU M to the target machine.

ROTU M is firmly screwed to the stand frame provided by the user or to a machine frame of the complete machine by means of the four supplied clamping claws. It is recommended to screw at four central points along the base plate of the enclosure with ISO4762 M8x35 screws of strength 8.8, screw locking with Loctite and a tightening torque of 25Nm, see Figure 5.

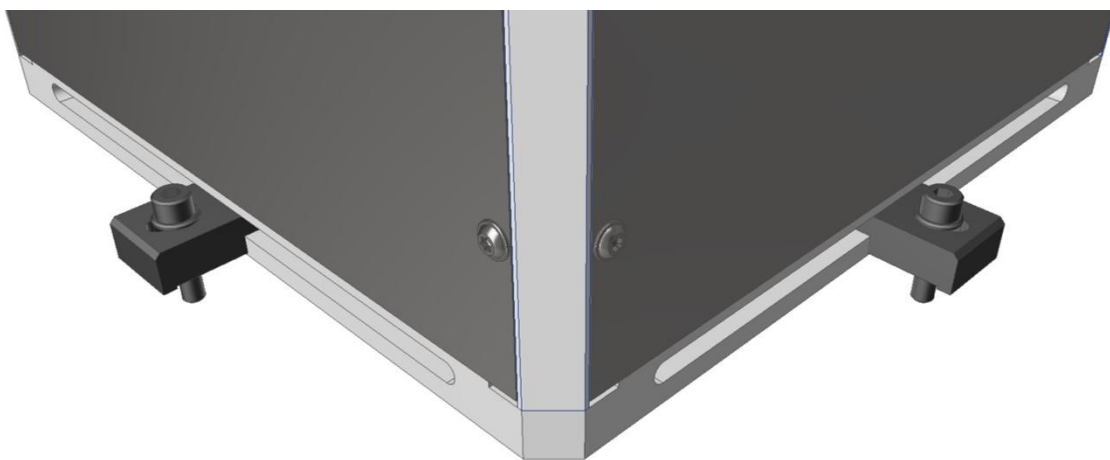

Figure 5: Bolting of the ROTU M with four clamping claws and ISO 4762 M8x35 screws

Make sure that the components of the ROTU M that are under vibration cannot touch other devices during operation.

## 3.3. Bringing into service



### Note!

The takeover of the provided workpiece after alignment and orientation via a tooling of the ROTU M must be secured by the customer.

### Before switching on for the first time:

Before switching on the ROTU M for the first time, check that

- The effective mass of the ROTU M can be moved freely without hitting the enclosure.
- ROTU M is cleanly bolted at the destination and aligned by means of a spirit level
- The tooling is bolted with torque according to the specifications in the technical data.
- The transport rod of the ROTU M is removed. Keep it in a safe place for the next transport.
- There are no objects or conveyed goods in the ROTU M yet.
- The available power supply (frequency, voltage, power) corresponds to the connection data of the control unit used.
- The control unit settings have been made to match the tooling according to the specifications.
- The connection cable of the ROTU M is plugged into the respective control unit and the protective conductor is connected.
- If compressed air is used for rapid emptying, the compressed air supply is connected.

**Attention!**

It must be ensured that the machine frame (stand, base frame, etc.) is connected to the protective earth conductor (PE). If necessary, a protective grounding must be carried out on site.

The electrical connection of the ROTU M and the components as well as the commissioning of the ROTU M may only be carried out by qualified personnel in accordance with the national regulations and provisions of the country in which the ROTU M is operated. When making changes to the electrical connection, be sure to observe the operating instructions for the control unit you are using.

Since ROTU M is a partly completed machine, the interaction between ROTU M and the user's pick-up station must be evaluated by the customer in a risk analysis. If measures are necessary as a result of this risk analysis, they must be implemented by the user. Emergency stop switches are not provided on the ROTU M. This function must be implemented by the manufacturer of the overall system/machine. Access to the circuit breakers must be free of obstacles at all times. The proper function of the circuit breakers must be checked daily at the start of machine operation.

**Attention!**

The ROTU M must not be put into operation until it has been completed with the complete machine and the safety requirements of the EC Machinery Directive for the complete machine have been met.

**The first switch on:**

After carrying out the previous steps, ROTU M is switched on without workpieces and at low amplitude (start value e.g. 10%). Step by step the amplitude is now increased to the target value belonging to the tooling. ROTU M must not hit the housing.

If ROTU M hits the housing, please check if

- A conveyed item is jammed between the substructure and the enclosure
- A sheet metal part of the housing is bent
- The transition to the downstream machine, e.g. linear conveyor or conveyor belt, is adjusted.
- Otherwise, please contact Rhein-Nadel Automation GmbH

**Note!**

The optimum conveying capacity of the ROTU M for one or more of the customer's conveyed goods has already been determined at the Rhein-Nadel Automation GmbH factory. We recommend not to deviate from the default values of amplitude and frequency for the corresponding tooling.

If ROTU M runs without problems at the target frequency and amplitude belonging to the tooling, the materials can be fed into the system according to the recommended filling quantity.

## 4. Operating Instructions

### 4.1. Operation

**When operating the ROTU M, the following points must be observed:**

1. The feeder is switched on and off via the control unit as standard. The user is free to connect this control in turn to his higher-level machine control.
2. a backlog of workpieces in the arrangement elements of the tooling must be avoided in any case, e.g. by stopping the ROTU M on the control side in case of filled buffer sections following the ROTU M.
3. When using compressed air on the tooling, the operating pressure must be kept constant and must not be switched off during operation. When switching on or restarting, it must be ensured that the operating pressure is safely present before ROTU M starts.
4. The set air and sorting nozzles must not be changed.
5. Accessibility to the ROTU M must be ensured for the operating personnel.
6. jammed workpieces may only be removed from the ROTU M if it has been completely switched off beforehand. This procedure must be carried out without destroying the workpiece and the tooling! ROTU M is a precision machine, damage to the tooling in the range of tenths of a millimeter can already cause functional impairments.
7. The ROTU M must not be overloaded with workpieces. The maximum filling weight or the maximum filling quantity is supplied as a recommendation with the tooling.
8. if the instructions in this operating and assembly manual are observed, ROTU M is maintenance-free.

**Note!**

ROTU M may only be operated by trained specialist personnel. The instructions in these operating and assembly instructions must always be observed. The operating personnel of the operator of the ROTU M can be trained by Rhein-Nadel Automation GmbH. Please ask for the conditions for such a training measure if require.

**Note!**

Depending on the material being conveyed, the ROTU M may be very noisy. The use of ear protectors is therefore recommended for work on and in the vicinity of the ROTU M.

**Attention!**

It should not be assumed that the stopped ROTU M is a safe device. Stored energy of the leaf springs can be released unintentionally or by improper maintenance procedures. This applies in particular to procedures which can be dangerous if they are carried out contrary to the recommendations of these assembly instructions during operation of the machine, e.g. removal of a jam.

## 4.2. Tooling change

When changing the tooling of the ROTU M, the following points must be observed:

1. switch off the ROTU M, switch off the compressed air supply.
2. loosen the fastening screws of the tooling and, if necessary, of the inserts on the inner helix and remove them
3. disconnect the compressed air connections, if necessary
4. store the old tooling at the designated storage location that meets the requirements of Chapter 5 of these operating and assembly instructions
5. carry out rapid emptying to remove the old material. To do this, place a container large enough to hold the old material remaining in the ROTU M under the quick emptying pocket and remove the insertion slide of the base.
6. Set the rapid emptying frequency and start the ROTU M.
7. run the ROTU M until all old material is removed from the system
8. switch off the ROTU M and check if old materials are jammed somewhere, especially between base plate and housing
9. insertion of the insertion slide
10. mounting the new tooling as well as any new inserts on the inner helix. When mounting the toolings on the ROTU M, the following screws and washers are recommended: ISO 4762 M8x25, tightening torque in Alu/Ensat: 25Nm, Loctite medium strength, washer according to ISO 125, form B. Connection and adjustment of possibly existing compressed air nozzles according to recommendation.
11. feeding of the conveyed goods and operation of the ROTU M according to chapter 4.1 of these operating and assembly instructions.

## 4.3. Maintenance intervals and time limits

ROTU M is designed for automatic continuous operation. Information on the wear of the tooling cannot be given, as this varies depending on the ROTU M system - tooling - material conveyed. The recommended maintenance intervals are as follows:

1. daily: visual inspection of the ROTU M for jammed conveyed goods or damaged elements.
2. weekly or as required: cleaning of ROTU and tooling
3. semi-annually: basic cleaning of the ROTU with removal of the cladding and cleaning of the interior of ROTU M

The following agents are recommended for cleaning:

Part to be cleaned	Cleaning agent	Cleaning method
ROTU M base ROTU M inner helix	Soap suds or Iso-propanol	Wipe off abrasion with damp cloth, allow to dry
Tooling (aluminum, hard anodized or steel, plasma nitride)	Soap suds or Iso-propanol	Wipe off abrasion with damp cloth, allow to dry
ROTU M Enclosure (plexiglass parts)		Wipe off abrasion with damp cloth, allow to dry
ROTU M Enclosure (metal parts)	Soap suds or Iso-propanol	Wipe off abrasion with damp cloth, allow to dry

**Attention!**

For all maintenance work the ROTU M must be disconnected from the mains.

**Note!**

Maintenance work to remove jammed materials must only be carried out when the ROTU M is stationary!

## 5. Storage, Dismantling, Disposal

The storage of the ROTU M or the toolings must be dry and protected from aggressive media or dirt. Strong temperature fluctuations must be avoided. After a longer period of storage, cleaning must be carried out according to chapter 4.3 of these operating and assembly instructions.

To dismantle the ROTU M from the destination, first disconnect the power and compressed air supply. Remove all conveyed goods from the system. Attach the transport rod and remove the clamping claws on the base plate. For the rest, observe the instructions in chapter 3.1 "Transport". For a return of the ROTU M to Rhein-Nadel Automation GmbH we recommend the use of the transport box.

The components of the ROTU are made of steel, stainless steel and aluminum. The inner spiral, base and quick discharge are made of polyamide. The enclosure of the ROTU is made of stainless steel and Plexiglas. The corner connectors and the cover of the ROTU are made of additively manufactured PA12. Information on the material of the purchased parts can be found in the supplier documents. Units that are no longer usable should not be dismantled and recycled as a whole unit, but rather in individual parts and according to the type of materials specified. Please contact Rhein-Nadel Automation GmbH if you wish to return the ROTU.

## 6. Troubleshooting

Q „I have assembled ROTU M according to the instructions in these operating and assembly instructions, but the ROTU M does not run"

A First of all, check that...

1. the settings on the control unit are correct (frequency, amplitude)
2. the tooling is installed in original condition without removed or additionally attached masses
3. the tooling is mounted with the target value of 25Nm
4. the correct conveyed goods are present in the ROTU M with the specified number and are not jammed anywhere and impair the movement of the ROTU M
5. the bolting of the inner helix by means of the eight M12 bolts present corresponds to the target value of 70Nm.
6. the ROTU M is aligned horizontally
7. after removing the metal sheets of the enclosure: the magnetic gap is set to 3mm and the magnet armature and solenoid are screwed with the target value of 14Nm and heavy washers.
8. the leaf springs are damaged

If none of these measures helps, try to get the ROTU M running by adjusting the excitation frequency. to run by adjusting the excitation frequency. Contact the Rhein-Nadel Automation GmbH

Q "We have problems with different batches of conveyors"

A Record the geometric deviations of the individual conveyor belt batches from the target material to be conveyed. Share these results to Rhein-Nadel Automation GmbH and request optimized tooling for these fluctuating conveyor batches.

Q „We would like to optimize the position of the rapid discharge“

A You can choose from four quick emptying positions, each offset by 90°. To change the position of the quick emptying unit, you only have to move the plates of the housing to the desired position and loosen, rotate and reassemble the base of the ROTU accordingly.

Q „We have detected a defect in the ROTU M and need spare parts. How do we obtain them?"

A In principle, each part of the ROTU M can be reordered individually. Only the suspension struts are only available as a pre-assembled component. In case of replacement, please contact Rhein-Nadel Automation GmbH, [www.rna.de](http://www.rna.de) directly

## 7. Spare and wear parts

In principle, each part of the ROTU M can be reordered individually. Only the suspension struts are only available as a pre-assembled exchange assembly. However, for the fastest service we recommend sending an identical ROTU\_M - tell us the serial number of your ROTU, we will send you an identical system and rework the old ROTU in our factory. In case of replacement, simply contact Rhein-Nadel Automation GmbH directly: [vertrieb@rna.de](mailto:vertrieb@rna.de)

part	Ident-Nr.
Suspension strut ROTU_M	1122
Base ROTU_M	1310
Quick emptying ROTU_M	1312
Inner helix ROTU_M_LL	1315
Inner helix ROTU_M_RL	1316
Corner connector long ROTU_M	1343
Corner connector short ROTU_M	1345
Electromagnet Kendrion OAC009.504201	1615



**Hauptniederlassung:**  
Rhein-Nadel Automation GmbH  
Reichsweg 19-23  
D-52068 Aachen  
Tel.: +49 (0) 241-5109-0  
Fax: +49 (0) 241-5109-219  
E-Mail: [vertrieb@RNA.de](mailto:vertrieb@RNA.de)  
[www.RNA.de](http://www.RNA.de)

*Weitere Unternehmen der RNA-Gruppe:*



PSA Zuführtechnik GmbH  
Dr.-Jakob-Berlinger-Weg 1  
D-74523 Schwäbisch Hall  
Tel.: +49 (0) 791 9460098-0  
Fax: +49 (0) 791 9460098-29  
E-Mail: [info@psa-zt.de](mailto:info@psa-zt.de)  
[www.psa-zt.de](http://www.psa-zt.de)



RNA Automation Ltd.  
Unit C  
Castle Bromwich Business Park  
Tameside Drive  
Birmingham B35 7AG  
United Kingdom  
Tel.: +44 (0) 121 749-2566  
Fax: +44 (0) 121 749-6217  
E-Mail: [RNA@RNA-uk.com](mailto:RNA@RNA-uk.com)  
[www.rnaautomation.com](http://www.rnaautomation.com)



HSH Handling Systems AG  
Wangenstr. 96  
CH-3360 Herzogenbuchsee  
Schweiz  
Tel.: +41 (0) 62 956 10-00  
Fax: +41 (0) 62 956 10-10  
E-Mail: [info@handling-systems.ch](mailto:info@handling-systems.ch)  
[www.handling-systems.ch](http://www.handling-systems.ch)



Pol. Ind. Famades c/Energia 23  
E-08940 Cornellà de Llobregat (Barcelona)  
Spanien  
Tel: +34 (0)93 377-7300  
Fax: +34 (0)93 377-6752  
E-Mail: [info@vibrant-RNA.com](mailto:info@vibrant-RNA.com)  
[www.vibrant-RNA.com](http://www.vibrant-RNA.com)  
[www.vibrant.es](http://www.vibrant.es)



RNA Digital Solutions in München  
RNA Digital Solutions GmbH  
Agnes-Pockels-Bogen 1  
80992 München  
Telefon: +49 (0) 1515 / 99 28 255  
E-Mail: [kontakt@rnadigital.de](mailto:kontakt@rnadigital.de)  
[www.designforfeeding.com](http://www.designforfeeding.com)  
[www.rnadigital.de](http://www.rnadigital.de)

*Weitere Produktionsstandorte  
der RNA-Gruppe:*

*Werk Lüdenscheid*

Rhein-Nadel Automation GmbH  
Nottebohmstraße 57  
D-58511 Lüdenscheid  
Tel.: +49 (0) 2351 41744  
Fax: +49 (0) 2351 45582  
E-Mail: [werk.luedenscheid@RNA.de](mailto:werk.luedenscheid@RNA.de)

*Werk Ergolding*

Rhein-Nadel Automation GmbH  
Ahornstraße 122  
D-84030 Ergolding  
Tel.: +49 (0) 871 72812  
Fax: +49 (0) 871 77131  
E-Mail: [werk.ergolding@RNA.de](mailto:werk.ergolding@RNA.de)

*Werk Remchingen*

Rhein-Nadel Automation GmbH  
Im Hölderle 3  
D-75196 Remchingen-Wilferdingen  
Tel.: +49 (0) 7232 7355558  
E-Mail: [werk.remchingen@RNA.de](mailto:werk.remchingen@RNA.de)