

Operating Instructions

for

Linear Feeders

SLS 250

SLS 400

SLS 600

SLS 800

Table of Contents

1.	Safety Information	4
1.1.	Fundamental safety directives	4
1.1.1.	Electrical connection	4
1.1.2.	Hazard points	4
1.2.	Intended use	5
1.3.	Explanation of symbols and notices	5
1.4.	Applicable directives and standards	5
2.	Description of the type SLS linear feeder	5
2.1.	General	5
2.2.	6	
2.3.	Technical data	6
3.	Shipping and handling	7
3.1.	Shipment ex works	7
3.2.	On-site moving	7
4.	Commissioning	8
4.1.	Installing the unit	8
4.2.	Design of feed rails	8
4.3.	Flexible add-on solutions	9
4.3.1.	Mounting a feed rail	9
4.3.2.	Mounting of two feed rails	10
4.3.3.	Mounting of split feed rails	10
4.4.	Equipment-specific adjustments	11
4.4.1.	Balancing the masses	11
4.4.2.	Adjusting the natural frequency	12
4.4.3.	Adjusting the air gap	13
5.	Maintenance	13
6.	Spare parts list	14
7.	Disposal	14



Declaration of Incorporation

according to Machinery Directive 2006/42/EC

We,
Company

Rhein-Nadel Automation GmbH
Reichsweg 19-23
52068 Aachen
Germany

herewith declare under our sole responsibility that with regard to the following product:

Machine designation: (function)	Linear feeder
Type designation:	SL(...) GL(...)
Serial number	10865660 0001 2500000 0001

all relevant essential safety and health requirements of Directive 2006/42/EC have been fulfilled up to the battery limits.

The product to which this declaration refers is furthermore in conformity with following directives and standards or other regulations:

2006/42/EC	Machinery		
2006/95/EC	Low Voltage		
2014/30/EU	Electromagnetic Compatibility		
EN 614-1	2006+A1:2009	EN ISO 13857	2008
EN 619	2002+A1:2010	EN ISO 14120	2015
EN 620	2002+A1:2010	EN 60204-1	2006
EN ISO 12100		2010	

The relevant technical documentation has been compiled in accordance with Annex VII B of the Machinery Directive and on request, such documentation will be transmitted to the competent authorities in hard copy.

Nico Altmeyer, Rhein-Nadel Automation GmbH, Reichsweg 19-23, 52068 Aachen

(Name and address of person authorised to compile the relevant technical documentation)

Notice: This machine must not be put into service until the complete system into which it will be incorporated has been declared to be in conformance with the provisions of the Directive.

Signatory information

Name: Dr. Hensen

Given name: Tobias

Function: Managing Director

Germany
Aachen,

Place and date

Signature

1. Safety Information

1.1. Fundamental safety directives

These operating instructions constitute the basis for safe use and operation of the SLS type linear feeder. This instruction manual, and in particular the safety information it contains, must be observed by all persons who work with or on the SLS feeder. Furthermore, the accident prevention rules and regulations that apply at the place of use must be observed. Always keep the operating instructions readily available near the SLS feeder.

Only qualified workers are allowed to operate the equipment. Qualified workers are people who, due to their professional training, experience and schooling, as well as their knowledge of relevant standards, provisions, accident prevention regulations and operating conditions, have been authorized by the person responsible for the safety of the equipment to perform the required tasks and who can recognize and avoid potential hazards (definition for skilled persons according to IEC 364).

Faults which may affect the safety of persons, of the SLS feeder or of other property must be remedied immediately.

The following notices are for the safety of operators as well as the safety of the described products and any connected appliances.

1.1.1. Electrical connection

Notice

- Disconnect power supply before conducting assembly or disassembly tasks, and when altering the configuration.
- Observe applicable accident prevention and safety regulations relevant to the application concerned.
- Before putting into operation, check that the nominal voltage of the device is compatible with the local mains supply.
- Emergency OFF devices must remain effective in all modes of operation. Unlatching of Emergency OFF devices may not cause uncontrolled reactivation of the unit.
- Electrical connections must be kept covered!
- After installation, check that protective earth connections are functioning correctly!
- Connection must be made by authorized persons only.



1.1.2. Hazard points

Attention



The SLS type linear feeders have been designed according to the EC Machinery Directive, the state of the art and recognized safety rules. Nevertheless, their use may give rise to hazards for life and limb of the operator or third parties, or to damage of the SLS or other property. Due to its open connector design the SLS must not be used in following areas:

- a) in liquids. When installing the linear feeder make sure that the power cable of the motor is placed such that no liquid can collect where cable enters the encapsulated magnet.
- b) areas with highly inflammable substances.
- c) areas with explosive substances.

1.2. Intended use

The intended use of the SLS is exclusively the feeding and discharging of parts. It can also be used for orienting of parts. For maximum permitted dimensions and weights of add-on components observe the notices in chapter 2.3, table 1 'Technical Data' and chapter 3 'Commissioning'. Use to the intended purpose includes observance of all notices in these operating instructions.

The SLS must not be modified, extended or altered without the manufacturer's approval. The rails described in chapter 3.2 'Design of feed rails' and chapter 3.3 'Flexible add-on solutions' are excluded from this rule.



Notice

Any use beyond the above specifications or any modifications to the design are considered improper use and will void the warranty.

See also our general terms and conditions.

1.3. Explanation of symbols and notices



Notice

This symbol indicates notices on the proper use and economical operation of the equipment.



Attention

This symbol indicates risks to life and limb of persons, or risks of damage to the machine or equipment.

1.4. Applicable directives and standards

The linear feeder has been manufactured in accordance with the following directives:

- 2006/42/EC Machinery Directive
- 2014/35/EU Low Voltage Directive
- 2014/30/EU Electromagnetic Compatibility Directive

We assume that our product will be incorporated into a stationary machine.

The applicable standards are specified in the Declaration of Incorporation (according to Annex II B of the Machinery Directive).

2. Description of the type SLS linear feeder

2.1. General

The SLS type linear feeders are used to discharge the parts to be handled from upstream machines or to feed them to downstream machines. Allowing for various criteria, linear feeders are also used for orienting of parts. The linear feeders are installed in stand-alone feeding stations as well as in complex automated assembly systems.

The various linear feeder types differ in size and scope of application (see chapter 2 'Description of the SLS' and chapter 3.3, table 3 'Recommended values for max. part widths').



Notice

SLS type linear feeders must be operated in combination with a control unit to ensure optimum feeding behaviour. Functional description

2.2.

SLS type feeders consist of two vibrating sections arranged side by side and vibrating in opposing directions. These are connected via bifurcated leaf springs to a common base plate where the opposing vibratory forces virtually cancel each other out. Optionally, each of the vibrating sections can operate as useful or counter mass. Another option is to operate both as useful masses (see chapter 3.3 'Flexible add-on solutions'). A magnet system (armature - magnet core) is installed horizontally between the two vibrating sections. The advantages of the SLS linear feeders are based on the adjustable balancing of useful and counter masses which largely eliminates the free vibratory forces directly within the unit.

2.3. Technical data

Figure 1: Dimensions of SLS 250

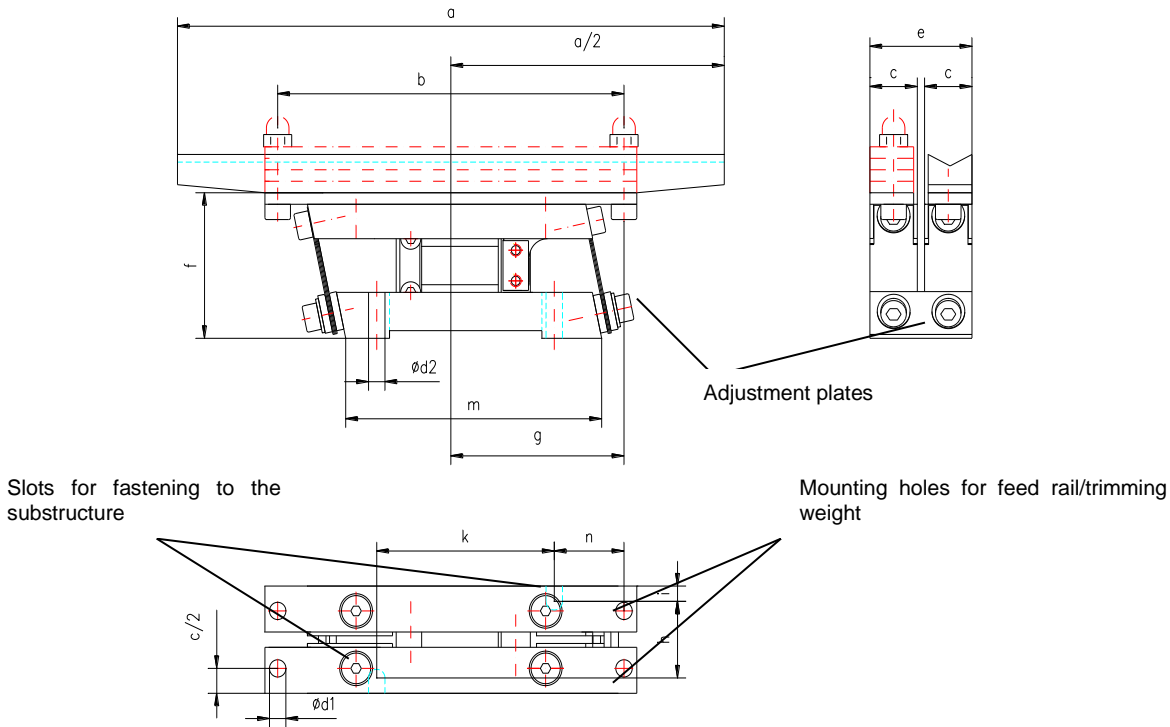

Figure 2: Dimensions of SLS 400 - 800

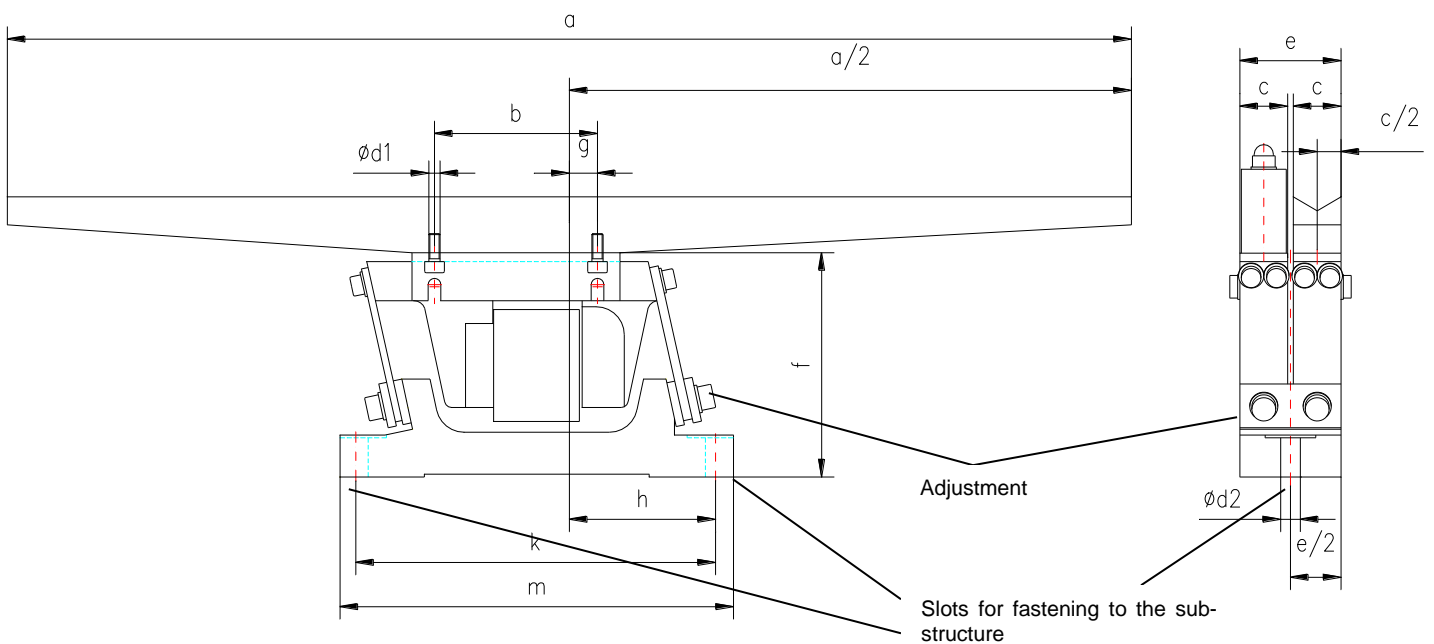

Table 1: Technical data

		SLS 250	SLS 400	SLS 600	SLS 800
Dimensions in mm.	a	150-250	200-400	300-600	500-800
	b	122	58	85	150
	c	17	17	24	29
	ød1	4.5	4.5	5.5	6.6
	ød2	4.5	7	9	10
	e	36	36	50	60
	f	49	79.7	111.7	139.7
	g	56	10	30	45
	h	28	52	88	133
	i	4	-	-	-
	k	75	128	177	283
	m	90	140	200	300
	n	17.3	-	-	-
Max. weight of feed rail [kg]		0.3	0.65	1.5	3.0
Weight of basic unit [kg]		0.7	1	2	7
Vibration frequency [Hz]	double the mains frequency				
Power supply [V / Hz]	230/50 or 110/60				
Max. power input [VA]		10	15	25	60
Degree of protection	IP 54				

Various sizes are available to suit individual application and spatial requirements (see table 1). The main determining criteria are the useful / counter masses and the space available for installation.

The linear feeders are available with 230 V / 50 Hz and 110 V / 60 Hz magnets. We also offer a range of controllers for the linear feeders.

3. Shipping and handling

3.1. Shipment ex works

The linear feeders are delivered ex works in a box or crate.

3.2. On-site moving

The weight of the linear feeder depends on its dimensions and motor rating. Please refer to the shipping documents for the weight of your specific equipment.



Attention

Check all guards when unpacking. Replace any damaged parts before commissioning!



Attention

For lifting the feeders be sure to use only sufficiently dimensioned vehicles, ropes, chains and sling gear.



Attention

Handling operations to be carried out only by employees who are capable of performing such work due to their own knowledge and experience in this field.



Warning

Warning against suspended loads

4. Commissioning

4.1. Installing the unit

Firmly bolt the SLS to the floor using the slots in the base plate (see Fig. 3). This allows for exact definition and adjustability of the junction points at the feed rail entry and exit. In the horizontal plane the floor should be non-yielding (plate or block construction) to absorb any residual forces in this plane. Cantilevered sectional steel structures must be reinforced with a baseplate on which the linear feeder is to be mounted. Best suited for this purpose is a steel plate at least 20 mm thick and more than 120 mm wide. Vertical vibratory forces, which are the primary source of floor vibrations, can be virtually eliminated through careful mass balancing (see chapter 3.4.1 'Balancing the masses'). Suitable substructures must be provided for height adjustment. Suitable standard components are available for complete station set-ups in combination with bowl feeders.

Fig. 3: Fixing slots in base plate

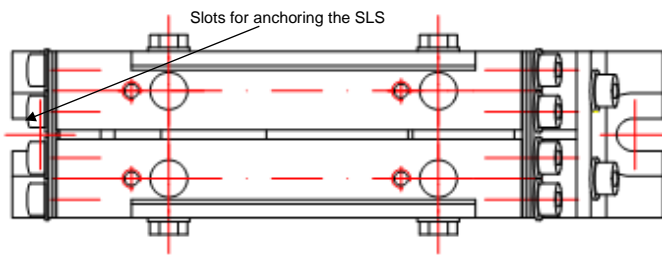

Attention

The linear feeder is intended to complete / to be incorporated into a complete system. Do not operate the machine before safe completion/incorporation by the user.

4.2. Design of feed rails

The feed rails must be unyielding so that the transport pulses generated by the unit are fully transferred to the parts to be handled and no superimposed natural vibration can adversely affect the transport process. This requirement has priority over mass reduction measures. The preferred material for feed rails is tool steel (e.g. 1.2842, 90MnCrV8). Linear track design should adhere to the useful masses specified in chapter 2, table 1 'Technical data' and chapter 3.4.1, table 4 'Recommended values for useful and counter masses with mass difference'.

The following feed rail cross sectional dimension ratio is recommended:

$$\frac{\text{Höhe}}{\text{Breite}} = \frac{2}{1}$$

The recommended dimensions are listed in Table 2. The dimensions are given for one vibrating section and applicable to each of the two vibrating sections.

Table 2: Feed rail dimensions

	SLS 250	SLS 400	SLS 600	SLS 800
Length	250 mm	400 mm	600 mm	800 mm
Width	17 mm	17 mm	24 mm	29 mm

4.3. Flexible add-on solutions

4.3.1. Mounting a feed rail

Mount the feed rail on the left or the right vibrating section using a mounting angle bracket or side plate (see Fig. 4). With the SLS 250, the feed rail mounts directly onto the vibrating section (see chapter 2.3, Fig. 1). In any case, make sure to observe the correct mounting position as shown in chapter 2.3, Fig. 1 and Fig. 2. Any deviations may adversely affect floor vibration.

Fig. 4: Mounting with bracket

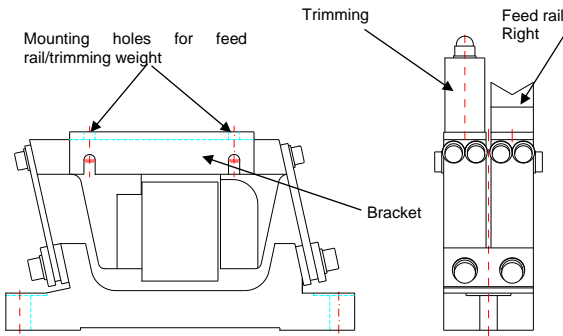
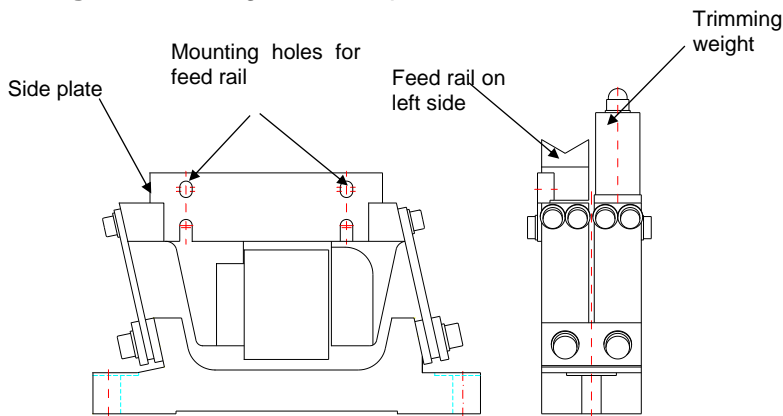

Fig. 5: Mounting with side plate



The vibrating sections are designed with outside recesses to receive the angle brackets and trimming weights. The discharge height of the feed rail can be precisely adjusted during initial installation by means of the oblong holes in the side plates. Thus no rail readjustment is required when the rail is removed and re-installed for cleaning or change-over to a different part type. Selection of the feed rail location on the left or right side is dependent on the installation and transfer requirements of the upstream or downstream equipment. Always mount the feed rail on the inside of the side plate. The weight of the feed rail (see chapter 3.4.1, table 4) and its mounting accessories (bracket or side plate) must be balanced by a counter mass (trimming weight) mounted to the second vibrating section.



Notice

For models SLS 250 and SLS 800 the useful and counter masses must always be identical. For models SLS 400 and SLS 600 there must be a specific difference between useful and counter masses. Observe the values specified in chapter 3.4.1, table 4, for useful and counter masses.

4.3.2. Mounting of two feed rails

Instead of the trimming weights (see Fig. 6) you can also mount a second feed rail, using brackets or side plates. Balance the masses as described in chapter 3.4.1 'Balancing the masses'.

Fig. 6: Linear feeder with two feed rails

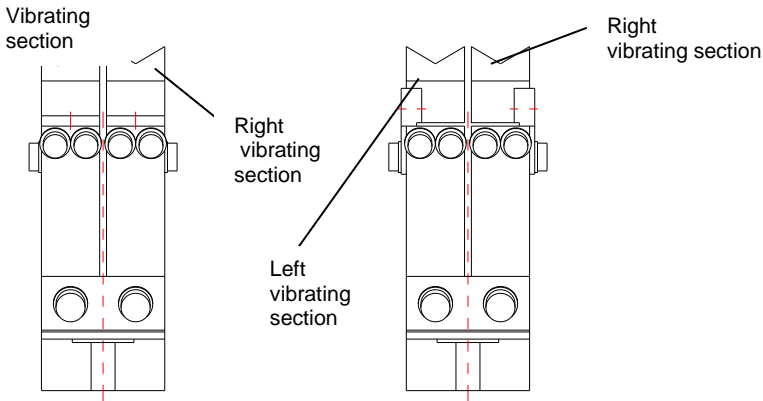

4.3.3. Mounting of split feed rails

If larger parts are to be handled it is possible to use a feed rail split in longitudinal direction, mounting each half onto the associated vibrating section. Balance the masses as described in chapter 3.4.1 'Balancing the masses'. In this case, the mass balance affects the conveying speeds of both feed rail sections and should be adhered to as exactly as possible. Larger parts can be conveyed smoothly as long as these conditions are observed. Guideline values for max. part widths are provided in table 3.

Figure 6: Linear feeder with split feed rail

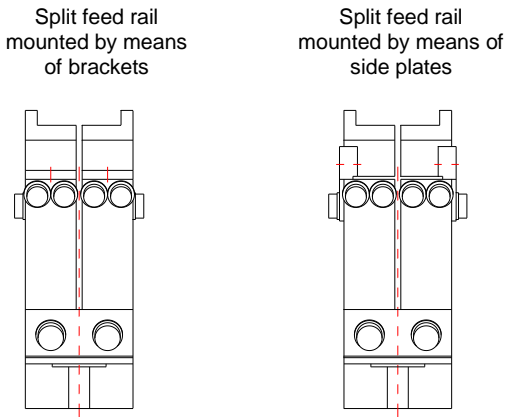

Table 3: Guideline values for max. part widths

Type	Max. width of parts to be conveyed
SLS 250	Approx. 30 mm
SLS 400	Approx. 50 mm
SLS 600	Approx. 70 mm
SLS 800	Approx. 80 mm

4.4. Equipment-specific adjustments

The first step in adjusting the linear feeders is always to balance the masses and then to adjust the natural frequency.

4.4.1. Balancing the masses

As a consequence of the opposite directions of vibration, the linear feeder virtually balances the vibratory forces in the base plate. However, this balance of vibratory forces is ensured only if useful and counter masses are adjusted to each other as precisely as possible. For models SLS 250 and SLS 800 this means that useful and counter masses must be identical. For models SLS 400 and SLS 600 there must be a specific mass difference between armature and magnet side. Table 4 below lists the armature side as the useful side so that there is a higher mass available for feed rail design.

The useful mass (i.e. the mass of the feed rail) is the total weight of all components attached to the feed rail side, including side plate or bracket. Accordingly, the counter mass is the total of all individual weights of the components on the counter side including side plate or bracket.

Mass balance is checked through simple weighing of useful and counter masses. Any additional weights required to reach the masses specified in table 4 must be attached in such a way that the distance between the mass centre points of useful and counter masses, viewed in a direction transverse to the transport direction, is as short as possible. In other words, if possible, the additional masses should not protrude laterally beyond the linear feeder as this would lead to increased residual vibration in the floor.

The masses are precisely balanced when hardly any vibrations are noticeable in the floor and the conveying speed of a part freely placed upon the feed rail or counter mass, is identical on both vibrating sides.

Table 4: Guideline values for useful and counter masses with mass difference

Type	Useful mass [kg] (armature side)	Counter mass [kg] (magnet side)	Difference [kg]
SLS 250	0.30	0.30	0.00±0.02
SLS 400	0.65	0.55	0.10±0.02
SLS 600	1.80	1.30	0.50±0.03
SLS 800	3.00	3.00	0.00±0.05



Notice

Observe the values specified in table 4 for useful and counter masses.



Notice

1. Masses are fully balanced when hardly any vibrations are noticeable in the floor.
2. When masses are fully balanced the feed rates at useful and counter side are identical.

4.4.2. Adjusting the natural frequency

The linear feeder is a spring-mass vibration system that operates utilising the resonance behaviour. Any changes in the mass require adjustment of the spring stiffness. For this purpose, sliding adjustment plates are provided on the spring assembly attachment at the base plate (see Fig. 8). You can adjust the natural frequency by moving these adjustment plates.

Fig. 7: Spring assembly with adjustment plates

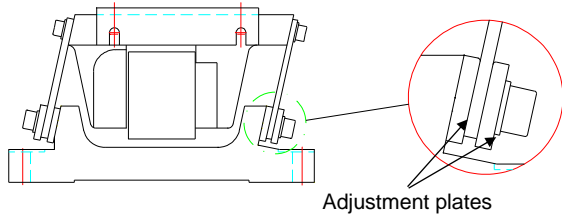

The linear feeder must always be tuned "subresonant", in other words, the natural frequency must be approximately 5 % above the driving frequency. For a 100 Hz feeder this translates to a natural frequency of around 104 Hz, for a 120 Hz feeder to one of about 126 Hz.

The tuning procedure is as follows:

Place a test part on the feed rail and switch on the controller. Use the rotary knob to reduce the feed rate of the linear feeder until the part on the feed rail only moves slowly. Keeping the controller setting constant, slowly loosen the adjustment plate screws on one feeder spring assembly (see Fig. 8). As you loosen the screws take care to check the feed speed of the test part. If the feed speed briefly increases initially and then decreases again as the screws are further loosened, the linear feeder is correctly tuned, i.e. its natural frequency is slightly above the driving frequency. Return the adjustment plates to the same position they were in before the screws were loosened.

If the feed speed increases while the screws are loosened and decreases only slightly or not at all when the screws are fully loosened, the linear feeder is tuned too stiff, i.e. its natural frequency is still too high. In this case, move the adjustment plates down or, if the weight deviation is too great, remove a leaf spring. Then repeat the test.

If the feed speed drops immediately while the screws are being loosened, the linear feeder is still tuned too soft. In this case, move the adjustment plates up or install an additional leaf spring as required. Then repeat the test.

When moving the adjustment plates make sure that they are always horizontal and always arranged exactly opposite each other.

Move adjustment plates up ⇒ Natural frequency increases
Move adjustment plates down ⇒ Natural frequency decreases



Attention

It is vital that the linear feeders be tuned in the subresonant region (i.e. the natural frequency must be about 5% above the driving frequency). Otherwise the magnet may overheat and burn out. Also the feed rate may decrease as soon as parts are placed on the feed rail.

When tuning the frequency, only loosen the adjustment plates of one spring assembly at a time to avoid subsiding of the vibrating sections.



Notice

Take care to align the adjustment plates horizontally. The top edges must always be arranged opposite each other.

4.4.3. Adjusting the air gap

During serial assembly, the air gap of the magnet system is set to the values specified in table 5. If it deviates from the values in table 5, e.g. after adjusting natural frequency, the air gap must be re-adjusted. To do so loosen the lateral fastening screws of the armature and re-adjust the air gap by means of a spacer plate.

Fig. 9: Armature fastening

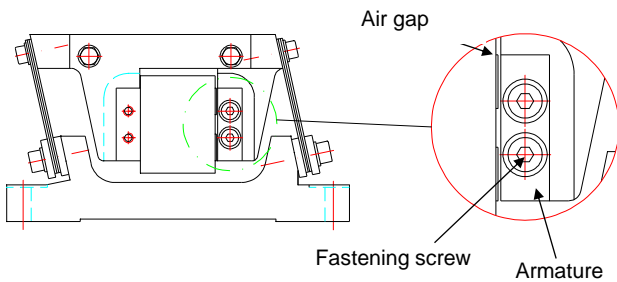

The values specified in table 5 apply only to the associated power supply. It is absolutely vital to ensure during adjustment that the faces of magnet core and armature are aligned exactly parallel to each another. To achieve the required accuracy, tighten the screws step by step and in turns.

Table 5: Setpoints for air gap between armature and magnet core

Type	Power supply	Air gap value	Tolerance
SLS 250	230 V / 50 Hz	0.8	± 0.05
	110 V / 60 Hz	0.6	± 0.05
SLS 400	230 V / 50 Hz	0.8	± 0.05
	110 V / 60 Hz	0.6	± 0.05
SLS 600	230 V / 50 Hz	1.0	± 0.05
	110 V / 60 Hz	0.6	± 0.05
SLS 800	230 V / 50 Hz	0.8	± 0.05
	110 V / 60 Hz	0.6	± 0.05



Notice

Setting an air gap larger than specified may cause the magnet to overheat and the coil to burn out. It is therefore vital that the specified air gaps be adhered to.

5. Maintenance

A type SLS linear feeder is virtually maintenance-free. In certain operating conditions, however, the leaf springs may oxidise which may affect the vibration behaviour in the long run. In such cases the leaf springs may need to be removed and cleaned. Only remove one spring assembly at a time as otherwise the vibrating sections are displaced and trouble-free operation is no longer guaranteed.



Notice

Never oil or grease the leaf springs as this would cause the leaves to stick together and thus impair the vibration behaviour.



Achtung

Attention

For installation, maintenance and repair work all poles of the power supply must be disconnected from the linear feeder in compliance with VDE provisions. Any work on electrical equipment of the linear feeder shall be carried out exclusively by a professional electrician, or by instructed persons (see chapter 2) working under the direction and supervision of a professional electrician, according to electrotechnical rules.



Attention

Be careful when working on linear feeders! The magnets can get hot during operation. Therefore let magnets cool down before working on them. If this is not possible, take suitable protective

measures such as the use of gloves.



Attention

If any guards have been removed, be sure to fit them back in place!

6. Spare parts list

As the SLS design comprises no wear parts, failure of individual feeder components is not likely to occur during use to the intended purpose. Should the need to replace individual components arise nonetheless, these must be ordered individually. For quick and correct handling of the spare part delivery please make sure to state the serial number of the unit in question.

7. Disposal

SLS feeders which are no longer in use should not be disposed of as complete units but dismantled and the component parts recycled according to their materials. Non-recyclable components must be properly disposed of.



Headquarters

Rhein-Nadel Automation GmbH
Reichsweg 19-23
D-52068 Aachen
Phone: +49 (0)241-5109-0
E-mail: vertrieb@RNA.de
www.RNA.de

Further RNA group companies:



PSA Zuführtechnik GmbH
Steinäckerstraße 7
D-74549 Wolpertshausen
Phone: +49 (0)7904-94336-0
E-mail: info@psa-zt.de
www.psa-zt.de



RNA Automation Ltd.
Unit C Castle Bromwich Business Park
Tameside Drive Birmingham B35 7AG
Great Britain
Phone: +44 (0)121-749-2566
E-Mail: sales@rnaautomation.com
www.rnaautomation.com



HSH Handling Systems AG
Wangenstraße 96
3360 Herzogenbuchsee
Switzerland
Phone: +41 (0)62-956 10-00
E-mail: info@handling-systems.ch
www.handling-systems.ch



RNA Vibrant S.A.
Carrer de l'Energia
08940 Cornellà de Llobregat (Barcelona)
Spain
Phone: +34 (0)93-377-7300
E-mail: info@vibrant-RNA.com
www.vibrant-RNA.com



RNA Digital Solutions GmbH
Reichsweg 19-23
D-52068 Aachen
Phone: +49 (0)1515-99 28 255
E-mail: kontakt@rnadigital.de
www.designforfeeding.com
www.rnadigital.de

Further manufacturing sites of the RNA Group

Lüdenscheid site

Rhein-Nadel Automation GmbH
Nottebohmstraße 57
D-58511 Lüdenscheid
Phone: +49 (0) 2351 -41744
E-mail: werk.luedenscheid@RNA.de

Ergolding site

Rhein-Nadel Automation GmbH
Ahornstraße 122
D-84030 Ergolding
Phone: +49 (0) 871 -72812
E-mail: werk.ergolding@RNA.de

Remchingen site

Rhein-Nadel Automation GmbH
Im Hölderle 3
D-75196 Remchingen-Wilferdingen
Phone: +49 (0)7232-7355-558
E-mail: werk.remchingen@RNA.de