

Installation instructions
for
Belt conveyors

FP 120
FK 120

Table of Contents

1.	Technical data.....	4
1.1.	Table.....	4
1.2.	Motor connection diagrams.....	5
1.2.1.	Constant-speed three-phase motor.....	5
1.2.2.	Constant-speed A.C. motor (with capacitor).....	5
1.2.3.	Variable-speed three-phase motor.....	6
1.2.4.	D.C. motor.....	6
2.	Safety directives.....	7
2.1.	Applicable directives and standards.....	9
3.	Design and functional description of belt conveyors.....	9
4.	Shipment and installation.....	11
4.1.	Shipment.....	11
4.2.	Installation.....	11
4.2.1.	One-piece belt feeders.....	11
4.2.2.	Installation of multi-segment belt feeders.....	11
4.2.3.	Installation on RNA supports.....	13
4.2.4.	Drive system (belt conveyors without RNA control units).....	14
4.2.5.	Preliminary adjustment of belt tracking.....	14
5.	Commissioning.....	15
5.1.	Adjustment of belt return station.....	15
5.2.	Adjusting the center drive station.....	16
5.3.	Adjusting at the head drive station (reserved only for exceptional situations).....	16
5.4.	Changing the sense of rotation.....	16
6.	Belt replacement.....	17
6.1.	Replacing a belt with head drive station.....	17
6.2.	Replacing a belt with center drive station.....	17
7.	Maintenance.....	18
7.1.	Belt.....	18
7.2.	Motor.....	18
7.3.	Gearbox.....	18
7.4.	Chain drive system.....	19
7.5.	Return, drive and supporting rollers.....	19
7.6.	Environmental effects.....	19
8.	Spare parts and customer service.....	19



Declaration of Incorporation

according to Machinery Directive 2006/42/EC

We hereby declare that our product is intended to be incorporated into or assembled with other machinery to constitute one machine in terms of the Directive indicated above (or parts thereof) and that it must not be put into operation until the relevant machinery into which it is to be incorporated has been declared to be in conformity with the EC Machinery Directive.

Applied harmonised standards: DIN EN 60204 T1, DIN EN ISO 12100-2011-03, DIN EN 619, DIN EN 620
DIN EN 1050

Remarks:

This product has been manufactured in accordance with the Low-Voltage Directive 2014/35/EU.
We assume that our product will be incorporated into a stationary machine.

Rhein-Nadel Automation GmbH
Managing Director

Dr. Tobias Hensen



1. Technical data

1.1. Table

Belt widths	(mm)	50, 80, 100, 120, 150, 200, 250, 300, 400, 500 (intermediate widths and widths > 500 are possible)
Belt lengths = shaft center distance	(mm)	500 to 12,000 (smaller sizes possible depending on design)
Conveyor load	(N/m)	100 standard rating (depending on motor, belt width and mode of operation (conveyance or accumulation) the total load may be much higher)
Constant belt speed Three-phase motor 230/400V ±10 %, 50/60Hz, IP54	(m/min.)	0.5, 1, 2, 3, 4, 5, 6, 7, 8, 10, 15, 20, 30, 50, 60, 80 (other speeds possible)
Constant belt speed A.C. motor 230V, 50/60Hz, IP54	(m/min)	0.5, 1, 2, 3, 4, 5, 6, 7, 8, 10, 15, 20, 30, 50, 60, 80 (other speeds possible)
Variable belt speed Three-phase motor with frequency control 230V or 400V, depending on VFD used	(m/min.)	0.25-1 / 0.5-2 / 1.25-5 / 2.5-10 / 5-20 / 7.5-30 / 15-60 / 20-80 (other speeds possible)
Variable belt speed D.C. motor 0-180V armature 200V field, IP54	(m/min.)	0.25-1 / 0.5-2 / 1.25-5 / 2.5-10 / 5-20 / 7.5-30 (other speeds possible)
Current input		see rating plate
Roller diameter	(mm)	return rollers 52 knife edges 8
Tensioning station		Integrated in belt return station and center drive station, with additional center tensioning station for belt lengths ≥ 5,000 mm

1.2. Motor connection diagrams

1.2.1. Constant-speed three-phase motor

Connection of three-phase motors

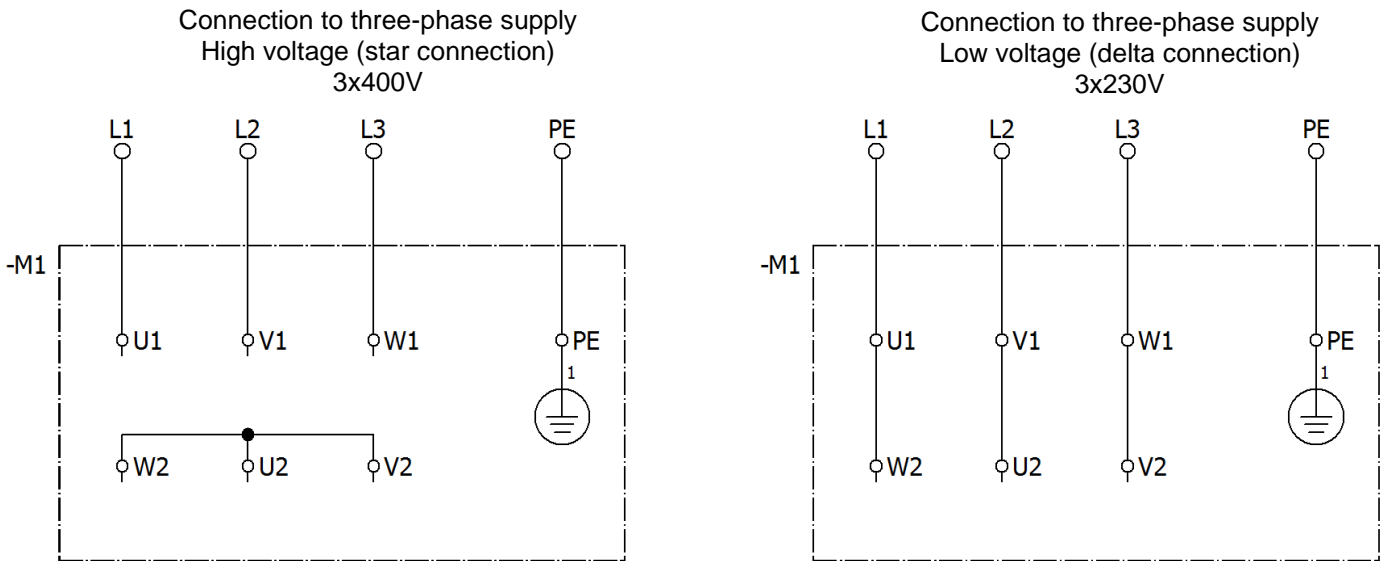

For reversing the sense of rotation change two phases of the supply line

1.2.2. Constant-speed A.C. motor (with capacitor)

Connection of three-phase motors

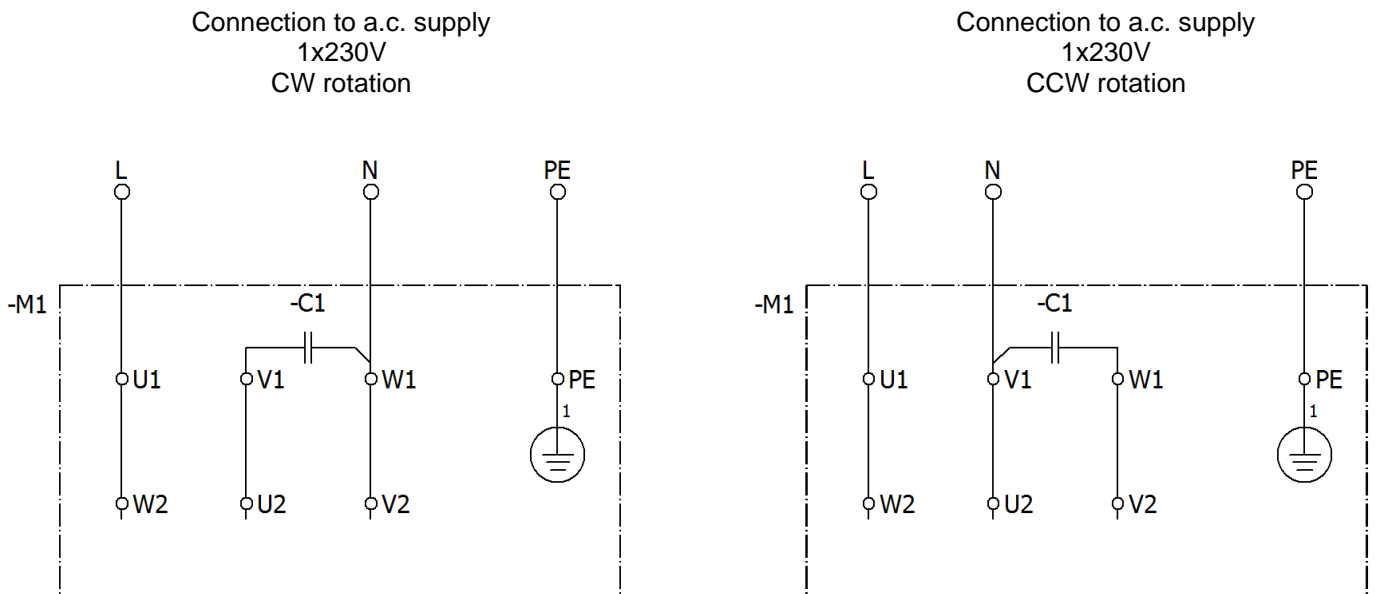

1.2.3. Variable-speed three-phase motor

Connection of variable-speed three-phase motors via variable frequency drive unit

Connection to three-phase supply
High voltage (star connection)
3x400V

Connection to three-phase supply
Low voltage (delta connection)
3x230V

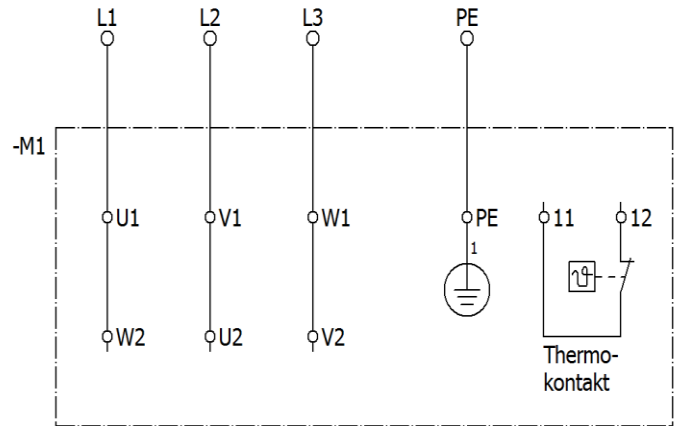
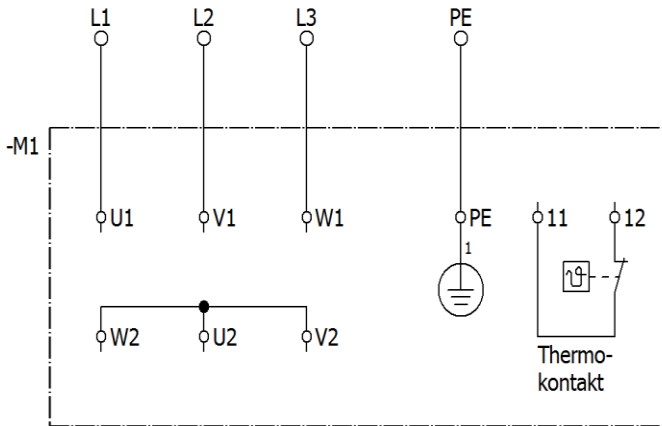

For reversing the sense of rotation change two phases of the supply line

1.2.4. D.C. motor

Connection of D.C. motors

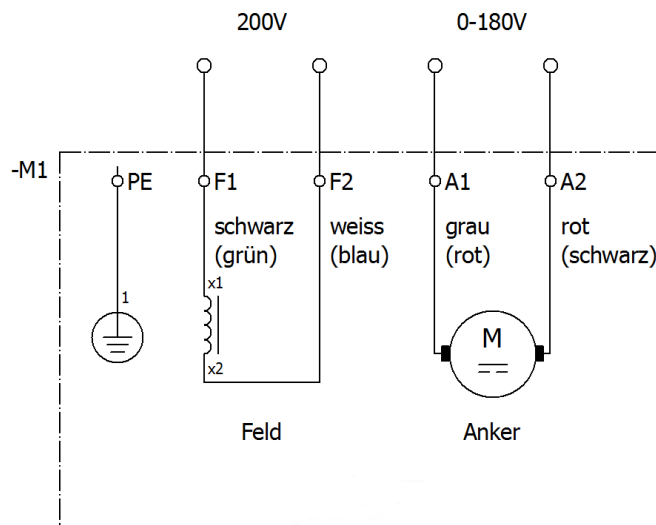

To reverse the sense of rotation invert the field leads.
(colour specs between parentheses apply to SN3FG)

2. Safety directives

We have taken great care in design and manufacture of our conveyors in order to ensure smooth and safe operation. You, too, can make an important contribution towards safety at work. We therefore ask you to read these brief operating instructions completely prior to commissioning the system. Observe the safety directives at all times!



Attention

This warning sign indicates safety directives. Non-observance of such warnings may cause serious injury or even death!



Caution

This warning sign indicates safety directives. Non-observance of this warning may cause minor injury or material damage.



Notice

This hand indicates useful tips for operation of the conveyors.

Make sure that all persons working with or at the equipment also read the following safety directives carefully and follow them!

These Operating Instructions only apply to the equipment types indicated on the cover page.

They must be available at all times at the place of installation of the conveyor.

If the conveyor is to be used in a humid or wet environment (wet area) make sure that the required degree of protection is provided.



Notice

For comprehensive information on the full range of control devices please refer to the 'Control Units' operating instructions.

Any commissioning, retooling, maintenance and repair work shall be carried out by qualified and authorized personnel only (see also 'Operator's duties' in this section).

For installation, maintenance and repair work all poles of the power supply must be disconnected from the conveyor in compliance with VDE provisions.

Any work on the electrical equipment shall be carried out exclusively by a professional electrician, or by instructed persons working under the supervision of a professional electrician, according to electrotechnical rules.



Attention

Risk of injury and electric shock hazard!

- The equipment user and operators shall ensure that only authorized personnel works at the conveyor.
- Any changes that have occurred on the feeding system affecting safety shall immediately be reported to the user.
- Operate the conveyor in perfect condition only.
- Use the belt conveyor only for its intended use.
- Observe the accident prevention provisions VBG 10 for continuous conveyors and VBG 4 for electrical equipment and components"

Machine hazards

- If the belt conveyor comes into contact with moisture or liquids there is risk of electric shock.
- Make sure that protective earthing of the power supply system is in perfect condition.
- Never operate the conveyor without guards and cover panels in place!

Intended use

The intended use of the belt conveyors is the feeding of parts.

The shortest side of such parts must be at least 5 mm long. Special versions or accessory equipment are available to modify the belt conveyors for use with parts having smaller side lengths (> 0.5 mm). If necessary, please contact the manufacturer.



Caution

Smaller parts may get under the belt and cause damage or failure of the belt conveyor.

Parts handled with standard belts must be dry, clean and without sharp edges. The handling of sharp-edged, oily, wet or hot (>70°C) parts requires the use of special belts.



Caution

For handling parts that may fall over, roll or slide, be sure to install sufficiently dimensioned side guides or slatted belts from our range of accessories.

The parts must not drop on the conveyor belt from height. The maximum permitted impact energy is 0.1 J.

If in doubt, please contact the manufacturer.

The belt conveyors are designed for horizontal transport at maximum loading. A slight inclination of the conveyor is possible in some cases. Please consult the manufacturer to determine what is possible for your specific application!

For permitted belt loading see Technical Data in section 1.

Noise emission

The constant sound pressure level is 70 dB(A) max. Specific part handling applications or belt designs may result in higher noise levels. For such exceptional cases noise abatement options are available from manufacturer.

Equipment user's duties

Commissioning, retooling, maintenance and repair work shall be performed by qualified and authorized personnel only.

We distinguish between four qualification levels:

Qualified personnel

refers to persons who are familiar with installation, start-up and operation of the conveyor. Their qualifications are appropriate for their activities.

Authorized personnel

refers to qualified personnel that has been assigned a clearly defined task by the user of the belt conveyor.

Qualified electrical worker

According to IEC 364 and DIN VDE 0105 Part 1, the term 'qualified electrical worker' refers to persons who, through their professional training, know-how and experience and through their knowledge of applicable standards are able to assess the work assigned to them and to recognize potential hazards.

Instructed person

According to IEC 364 and DIN VDE 0105 Part 1, the term 'instructed person' refers to persons who have been instructed in the tasks assigned to them by a qualified electrical worker. These persons have also been briefed on potential dangers resulting from inappropriate behaviour, and on the requisite guards and precautions to be used/taken.

2.1. Applicable directives and standards

The hopper has been manufactured in accordance with the following directives:

- EC Machinery Directive 2006/42/EC
- EC Low-Voltage Directive 2014/35/EU
- Electromagnetic Compatibility Directive 2014/30/EU

We assume that our product will be incorporated into a stationary machine. The requirements of the EMC Directive must be satisfied by the user.

The applicable standards are specified in the Declaration of Incorporation.

3. Design and functional description of belt conveyors

The belt conveyor bodies are made up of either special T-slotted aluminium profiles (FP120) or a folded sheet metal body (FK120).

FP120 profile body

FK120 sheet metal body

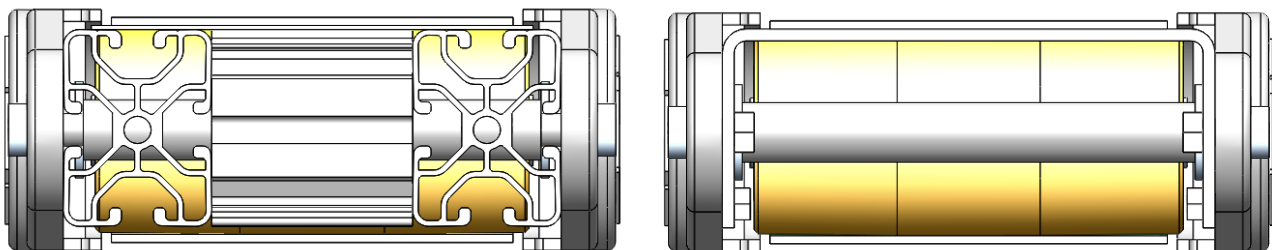

Fig. 1: Conveyor body types

Up to belt widths of 200 mm the conveyors can be fitted with knife edges at the entry and exit ends. If a knife edge is fitted it is not possible to arrange a drive station at the respective location. Belt tension and tracking are adjustable by means of the return roller arranged underneath the knife edge (see arrow).

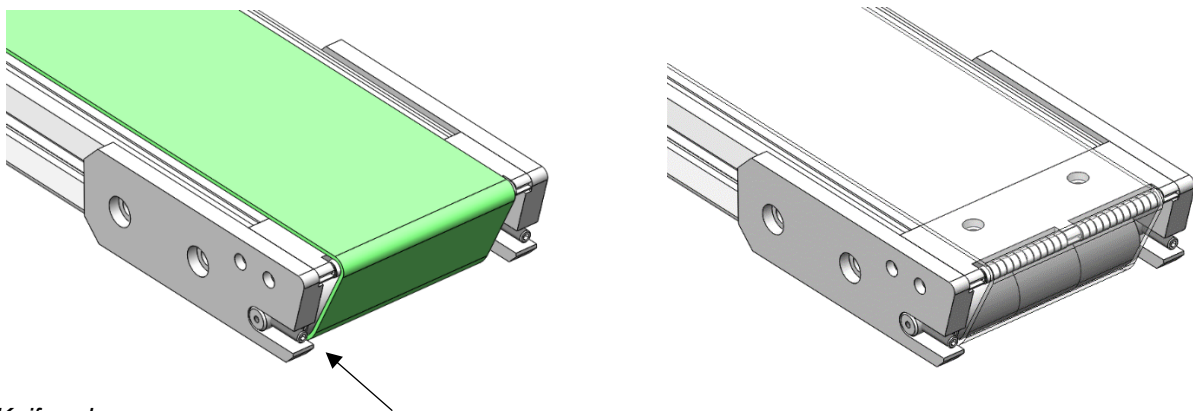

Fig. 2: Knife edge

For belt drive a number of motors are available for constant and variable speed. The motor may be arranged at the entry or exit end of the belt or in the middle. Drive stations can be attached to the belt conveyor in different ways. Control of the belt feeder is effected, depending on motor type, by motor protection breaker, electronic control devices or variable-frequency control units.

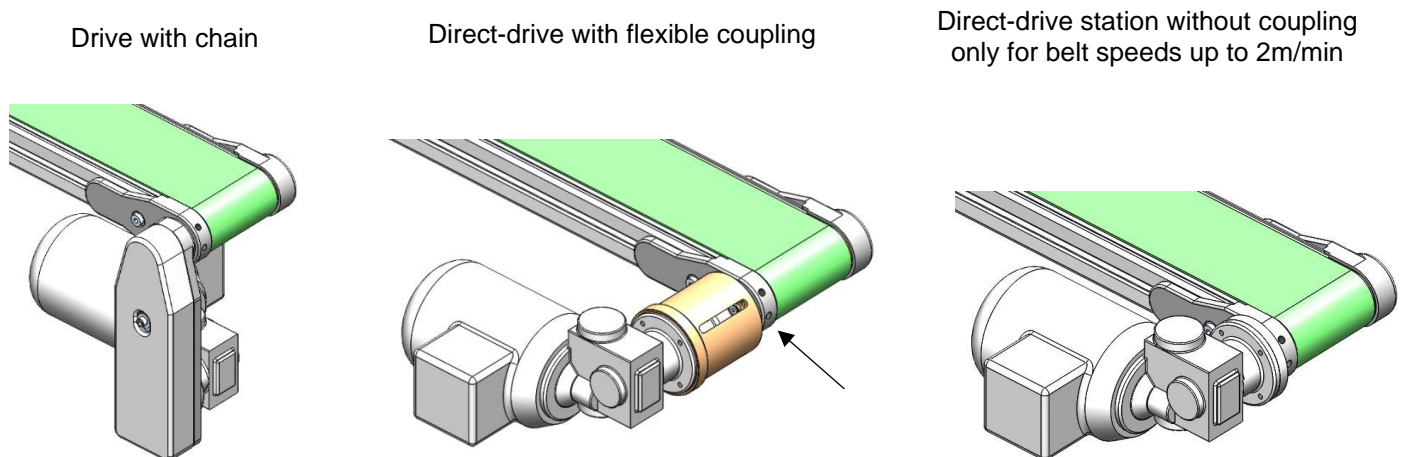

Fig. 3: Drive configurations

After loosening the setscrews (see arrow) you can rotate the drives on the driving roller shaft for variable motor positioning. Re-tighten the setscrews to fix it back in place. Adjusting the chain drive may affect chain tension. Therefore be sure to always check and adjust chain tension before restarting.



Notice

For information on the control devices please refer to the separate 'Control Units' operating instructions.

The brackets of the return station come with or without edge protectors. Brackets without edge protectors are smaller in size and are used when parts or side guides extend beyond the brackets, or for belts installed in hopper-type feeders. Belt tension and tracking are adjustable by means of the return roller (see arrow).

Brackets with edge protector

Brackets without edge protector

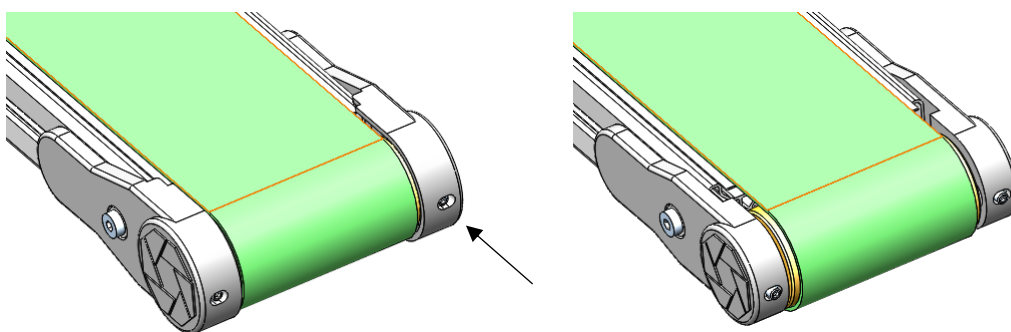

Fig. 4: Return station brackets

Depending on the application on hand the different belt feeders can be fitted with various accessories. These include cleated belts, anti-slip belts, reversible belts, angled belts, ESD versions, pharmaceutical versions, split conveyor bodies, side guides, top covers, sealing bars, supporting rollers, dirt trays, various support types etc.

4. Shipment and installation

4.1. Shipment

Shipment ex works

The belt conveyors are delivered ex works in cardboard or box packaging.

Handling on site

The belt conveyor weight depends on its dimensions and motor rating. Please refer to the shipping documents for the weight of your specific equipment.



Attention

Check all guards when unpacking. Replace any damaged parts before commissioning!



Caution

One-piece belt conveyors can be moved to their place of installation on a sufficiently strong trolley or cart. It is prohibited to move or handle multi-segment belt feeders in a fully assembled state!

4.2. Installation

4.2.1. One-piece belt feeders

One-piece belt feeders are delivered fully assembled. The procedure for installation on RNA-supplied supports is described in section 4.2.3.

4.2.2. Installation of multi-segment belt feeders

RNA belt feeders whose total length exceeds 3 m are delivered in segments due to packing and shipping considerations. The installation procedure for these belt feeders is described below.

Installation of the conveyor body

- Match the joints having the same numbers (Fig. 1).

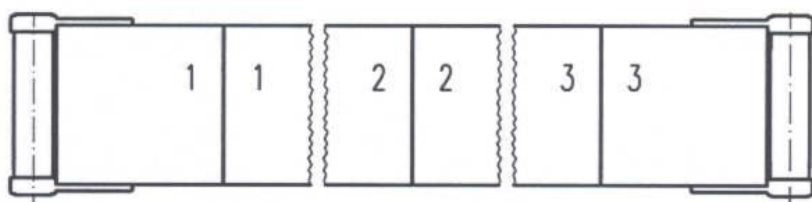

Fig. 5: Assembly of individual components

- If the skid plates are to be fixed in place with adhesive, peel the plastic coat off the double-sided bonding tape. Lift one conveyor body and slide it over the adjacent conveyor body so that their profiles are properly aligned and touch each other. In this position, press the skid plate onto the double-sided bonding tape. You can now join the conveyor bodies together by tightening the bolts (see arrow). Be sure to re-check the profiles for correct alignment.
- You can now slide the belt over the conveyor bodies from one side (observe notice below).



Notice

The standard belts are fabricated with finger joints to create a continuous belt. For such belts the conveying direction can be chosen freely.

For belts with overlap joints the conveying direction should be as shown below.

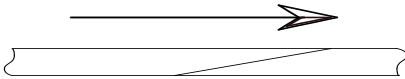

Fig. 6: Choice of conveying direction

Use of the belt for accumulation of parts is an exception. In this case, turn the belt.

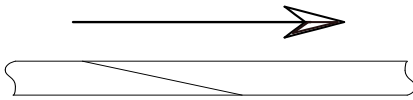

Fig. 7: Accumulation belt conveying direction

- Align the conveyor body segments with each other (Fig. 4).

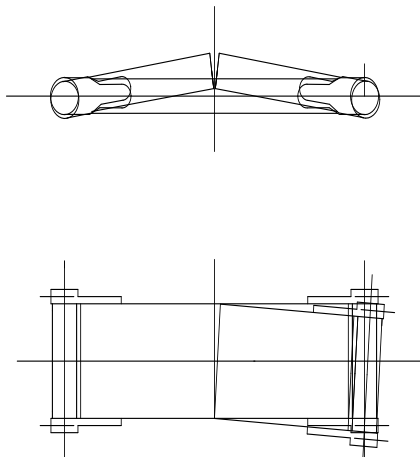

Fig. 8: Aligning the belt conveyor

- Join the conveyor body segments together.
- Align the drive and return rollers relative to one another and to the conveyor body (Fig. 9).

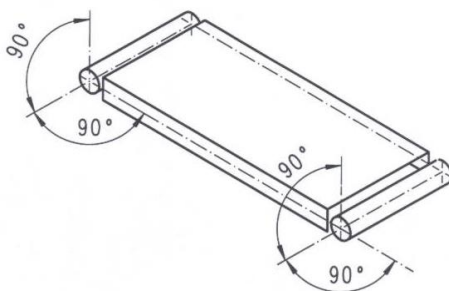

Fig. 9: Roller alignment



Caution

Install the guard enclosure **before** starting up the belt conveyor!

4.2.3. Installation on RNA supports

For installation of the belt conveyor on the RNA-supplied supports proceed as follows:

Double supports with FP120

With FP120-type conveyors, remove the slot nuts from the support brackets. Insert the slot nuts at the correct location on the conveyor body and place the body on the support brackets. Re-insert and tighten the screws.

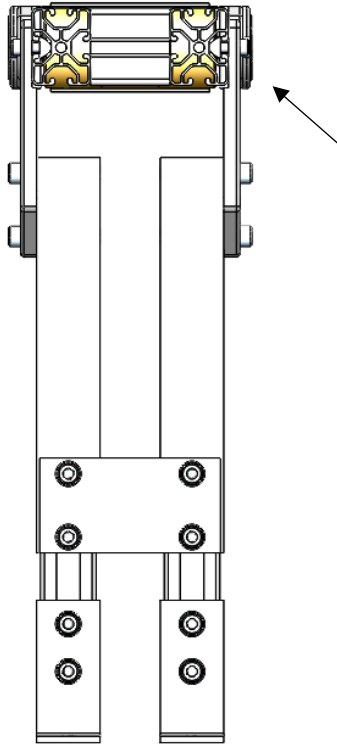

Single supports with FK120

With FK120-type conveyors, loosen the screws of the clamping brackets until you can fit the conveyor body between the support bracket and the clamping bracket. Then re-tighten the screws on the clamping brackets.

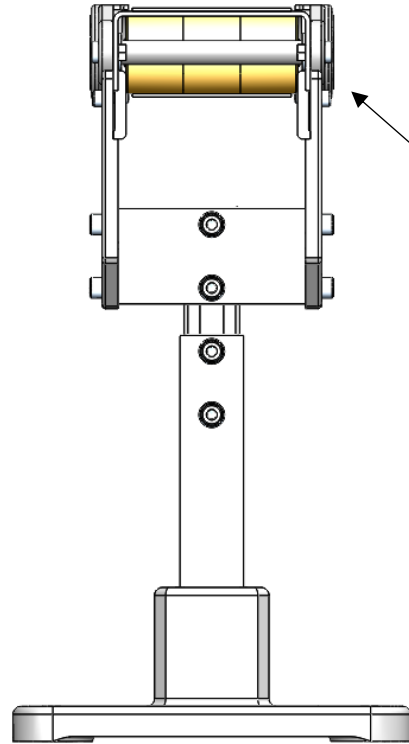

Fig. 10: Support types

- Adjusting the support height

The support height is adjustable by +70mm / -20mm. For shipping and handling the supports are always set to the lowest height. Distance from top of support brackets to conveyor passline:

FK 120 (sheet metal body): approx. 40 mm
FP 120 (aluminium profile body): approx. 11 mm

Loosen the screws on the support post. Slide the tubes in or out until you obtain the desired height. Re-tighten the screws.



Caution

Take care to prop up the top section of the support. When the screws are loosened the top section of the support may slide down under its own weight.
Risk of crushing injury!

- Place the support upright and align it.
- For double supports only:
Install the longitudinal brace to form a stable unit.
- Check that the tops of the support brackets are flush and level. If not, you can correct the angle of the support brackets after loosening the fastening screw. Remember to re-tighten the screws after making this adjustment!



Attention

It is absolutely mandatory to anchor the supports to the foundation. Operation of unanchored equipment is not permitted!



Notice

Make sure that once installed, the belt conveyor is free of distortion.

4.2.4. Drive system (belt conveyors without RNA control units)

Have a professional electrician connect the motor in accordance with the circuit diagram (see chapter 1). After that, check the sense of rotation.

**Attention**

Provide suitable overload protection for the motor. The characteristics of the motor can be found on its rating plate.

**Attention**

Be sure to check correct mounting of the chain guard before starting-up.

**Attention**

For gearboxes equipped with screw vents take care to screw in these vents before commissioning:
Replace the topmost screw plug by the screw vent supplied.

**Caution**

Motor protection breakers supplied unfitted must not be installed upside down as this would disable their protective function. Be sure to install the circuit-breakers in the specified orientation.

4.2.5. Preliminary adjustment of belt tracking

A preliminary adjustment of the belt tracking is necessary only after installation of belt conveyors supplied in multiple segments, and depending on the conveyor design:

Tensioning station integrated in belt return station

- Slacken the setscrews in the tensioning station on both sides of the conveyor such that the journals touch the ends of the oblong guide holes.
- Re-tighten the setscrews uniformly (count the revolutions!) until the belt is slightly taut.
- Start the motor. Continue to tighten the setscrews evenly until the belt travels without slipping on the driving roller at nominal load conditions.
- Adjust belt tracking as described in section 5.

**Notice**

If belt slipping occurs under operational load conditions, uniformly (count the turns!) tighten the tensioning screws until the drive shaft pulls the belt without slip.

Mid-way clamping station or center drive station

- Slacken the setscrews such that the journals touch the ends of the oblong guide holes.
- Tighten the setscrews on both sides of the conveyor uniformly (count the revolutions!) until the belt is slightly taut.
- Start the motor. Continue tightening one pair of setscrews of the same return roller uniformly until the driving roller drives the belt without slipping at nominal load conditions.
- Adjust belt tracking as described in section 5.

5. Commissioning



Attention

Electrical connection of the belt conveyor must be made by trained professional electricians only!
When making any change to the electrical connection be sure to observe the operating instructions for the motor circuit-breaker / control unit.

For starting and stopping the belt conveyor use the motor protection breaker fitted beside the motor.

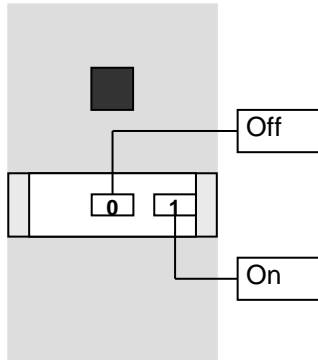

Fig. 11: Motor protection breaker

For belt conveyors ordered with other control units please refer to the separate control unit manual enclosed for operating instructions.

Motor and belt have undergone a trial run and final inspection in the factory. Due to re-installation on site and running-in of the belt it may be necessary to re-adjust belt tracking. If the belt runs off-centre after starting of the motor, first make the adjustment in the belt return station. If this is not enough, make the adjustment in the drive station.
The adjusting procedure is described in the following.

5.1. Adjustment of belt return station

Tighten the setscrew on that side towards which the belt is running (increasing belt tension) or slacken the setscrew on the opposite side (decreasing belt tension).

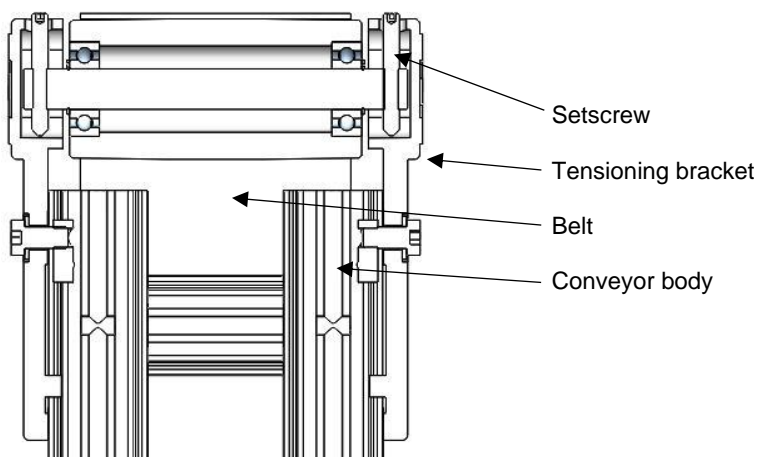

Fig. 12: Belt return station

5.2. Adjusting the center drive station

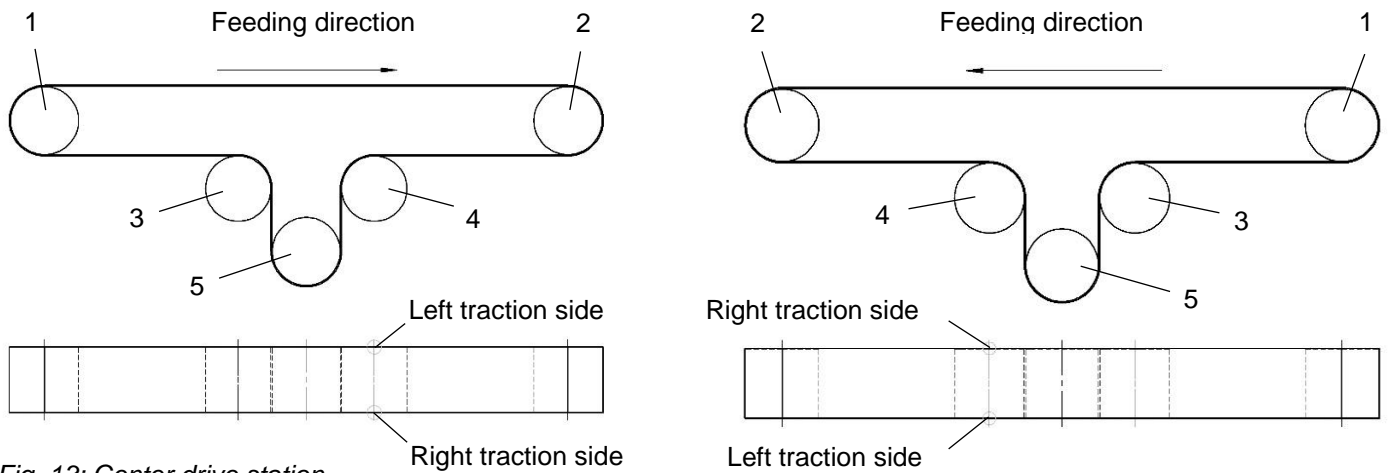

Fig. 13: Center drive station

Adjust tensioning stations 1 + 2 to parallel axes.

Position the tensioning rollers 3 + 4 of the center drive station in parallel and then tighten uniformly.

If you find the belt moving to the right, viewed in conveying direction, tighten the adjusting roller on the left traction side until the belt runs on line centre.

If the belt runs to the left, proceed accordingly on the right traction side.

5.3. Adjusting at the head drive station (reserved only for exceptional situations)

- Increase belt tension on the side towards which the belt moves by slackening the drive bracket and moving it horizontally, or
- decrease belt tension accordingly on the opposite side.
- Then re-tighten the bracket.



Caution

Too high belt tension may overload both the belt and the motor. After precise adjustment, measure the current drawn by the motor. If it is higher than the value shown on the rating plate, slacken the setscrews uniformly.

After adjustment is completed a trial run over several hours is mandatory. During the first running hours check that the belt runs on line centre at short intervals of time (about 2 to 3 times a day).

5.4. Changing the sense of rotation

With the motors used it is basically possible to change the sense of rotation. Sense of rotation is indicated by a red arrow on the chain guard. Remember to adapt this arrow accordingly when you change the sense of rotation. However, as for any change to the as-supplied condition, it is mandatory in all cases to observe the Equipment Safety Act and the regulations for the prevention of accidents.



Caution

Changing the direction of belt conveyors may render guard covers ineffective. Do not re-start before you have established compliance with the Equipment Safety Act and the regulations for the prevention of accidents.

When changing the direction of travel of conveyors whose belt has an overlap joint (see Fig. 6 on page 11) we recommend that you also dismount the belt and remount it in the other direction.

For belt tensioning and adjustment observe the procedures described in sections 4.2.5 and section 5.

6. Belt replacement



Attention

For installation, maintenance and repair work all poles of the power supply must be disconnected from the belt conveyor in compliance with VDE provisions. Any work on electrical equipment of the belt conveyor shall be carried out exclusively by a professional electrician, or by instructed persons (see chapter 2) working under the direction and supervision of a professional electrician, according to electrotechnical rules.

6.1. Replacing a belt with head drive station

- Slacken the setscrews in the tensioning station on both sides of the conveyor such that the journals touch the ends of the oblong guide holes.
- Measure the distance between tensioning station and conveyor body. Slacken the screws of the tensioning station brackets and slide the tensioning station towards the conveyor body.
- Pull the belt off the conveyor towards one side, and put on the new belt.
- Slide the tensioning station back into its previous position and re-tighten the screws of the brackets. Make sure that the top of the return roller is level with the skid plate.
- Re-tighten the setscrews uniformly (count the revolutions!) until the belt is slightly taut.
- Start the motor. Continue to tighten the setscrews evenly until the drive roller drives the belt without slipping at nominal load conditions.



Notice

If belt slipping occurs under operational load conditions, uniformly (count the turns!) tighten the tensioning screws until the drive shaft pulls the belt without slip.

- Adjust belt tracking as described in section 5.

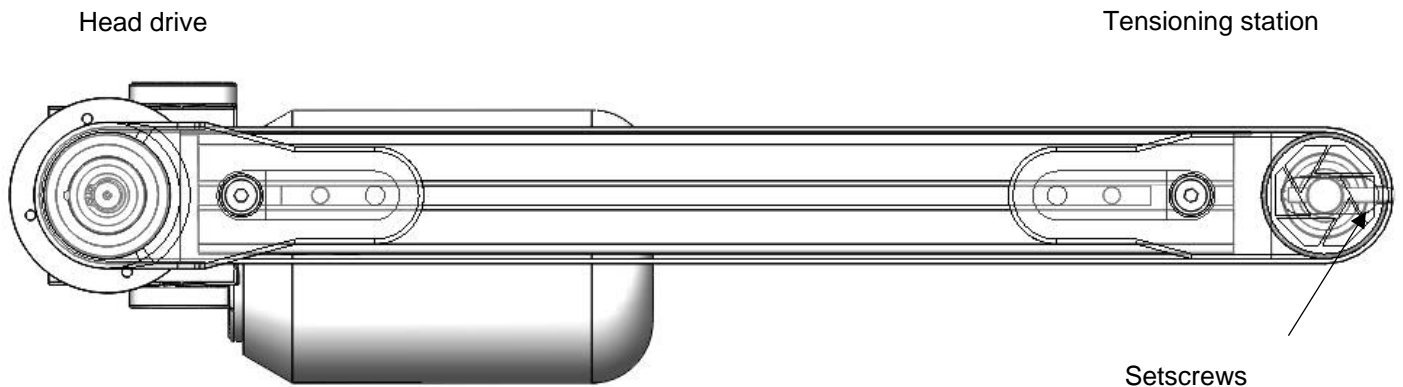

Fig. 14: Replacing a belt with head drive station

6.2. Replacing a belt with center drive station

- Completely remove all setscrews of the return rollers on the center drive station.
- Remove the two covers of the center drive station.
- Push one of the two return rollers towards the middle of the center drive station until you can pull out the two threaded plates. If you cannot remove the threaded plates because the return rollers are blocking the passage, slide the second return roller outwards and, if necessary, loosen the setscrews of the return rollers.
- You can now remove the return roller.
- Proceed in the same manner to dismount the second return roller.
- Pull the belt off the conveyor towards one side, and put on the new belt.
- Place the return rollers back in their guides and remount the threaded plates.
- Install the covers and setscrews of the center drive station.
- Re-tighten all loosened setscrews uniformly (count the revolutions!) until the belt is slightly taut.
- Start the motor. Continue to tighten the setscrews evenly until the drive roller drives the belt without slipping at nominal load conditions.



Notice

If belt slipping occurs under operational load conditions, uniformly (count the turns!) tighten the tensioning screws until the drive shaft pulls the belt without slip.

- Adjust belt tracking as described in section 5.

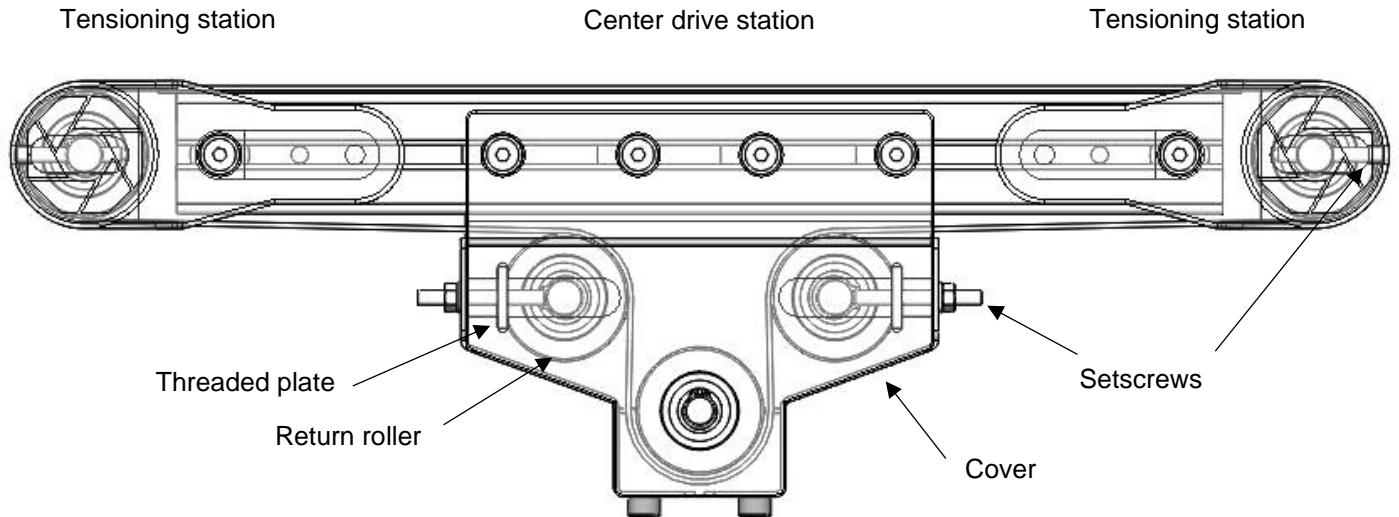

Fig. 15: Replacing a belt with center drive station

7. Maintenance



Attention

For installation, maintenance and repair work all poles of the power supply must be disconnected from the belt conveyor in compliance with VDE provisions. Any work on electrical equipment of the belt conveyor shall be carried out exclusively by a professional electrician, or by instructed persons (see chapter 2) working under the direction and supervision of a professional electrician, according to electrotechnical rules.

7.1. Belt

Clean soiled belt with spirit and a clean non-linting cloth. Where belts are used for food applications use an approved substitute for the spirit.



Attention

Take care to provide sufficient ventilation! Wear protective clothing.

7.2. Motor

For DC motors it is necessary to change the carbon brushes after 2000 hours run. After that, clean the surrounding area thoroughly.

Geared motors require no other maintenance for 10,000 operating hours.

Depending on dust accumulation, clean the motor fan cowl, the motor itself and the gearbox housing. This helps to ensure proper cooling of the motor.

7.3. Gearbox

The gearboxes are delivered ready-for-operation with gear oil and grease. This ensures long-life lubrication of all moving components.

No need for dismounting, cleaning and grease change.

7.4. Chain drive system

Check the tension of the drive chain at regular intervals depending on load conditions. Re-grease the chain at regular intervals.

Use a commercially available chain grease.



Notice

Check chain tension at regular intervals.

Remove the chain guard and clean the sprockets and chain of dirt and lubricant residue. Take care to remount the chain guard.



Caution

Be sure to check correct mounting of the chain guard before restarting the unit.

7.5. Return, drive and supporting rollers

Clean soiled rollers with spirit and a clean non-linting cloth. Where belts are used for food applications use an approved substitute for the spirit.



Caution

Take care to provide sufficient ventilation! Wear protective clothing.

7.6. Environmental effects

When positioning the belt conveyors take care that belts are not subjected to strong heat radiation. Observe the admissible belt temperatures (see brochure). Otherwise the belts may expand and slip over the drive roller.

Keep oil, chips etc. away from belt conveyors.

8. Spare parts and customer service

For an overview of genuine spare parts available please refer to the separate spare parts list.

In order to make sure that your order is processed swiftly and correctly please specify the device type (see rating plate), the quantity required, the spare part designation and the spare part number.

For a list of Service Center addresses refer to the back cover page of this manual.



Headquarter

Rhein-Nadel Automation GmbH
Reichsweg 19-23
D-52068 Aachen
Tel.: +49 (0)241-5109-0
E-Mail: vertrieb@RNA.de
www.RNA.de

Further RNA group companies:



PSA Zuführtechnik GmbH
Steinäckerstraße 7
D-74549 Wolpertshausen
Tel.: +49 (0)7904-94336-0
E-Mail: info@psa-zt.de
www.psa-zt.de



RNA Automation Ltd.
Unit C Castle Bromwich Business Park
Tameside Drive Birmingham B35 7AG
United Kingdom
Tel.: +44 (0)121-749-2566
E-Mail: sales@rnaautomation.com
www.rnaautomation.com



HSH Handling Systems AG
Wangenstraße 96
3360 Herzogenbuchsee
Switzerland
Tel.: +41 (0)62-956 10-00
E-Mail: info@handling-systems.ch
www.handling-systems.ch



RNA Vibrant S.A.
Carrer de l'Energia
08940 Cornellà de Llobregat (Barcelona)
Spain
Tel: +34 (0)93-377-7300
E-Mail: info@vibrant-RNA.com
www.vibrant-RNA.com



RNA Digital Solutions GmbH
Reichsweg 19-23
D-52068 Aachen
Tel.: +49 (0)1515-99 28 255
E-Mail: kontakt@rnadigital.de
www.designforfeeding.com
www.rnadigital.de

*Further manufacturing sites
of the RNA Group:*

Lüdenscheid branch

Rhein-Nadel Automation GmbH
Nottebohmstraße 57
D-58511 Lüdenscheid
Tel.: +49 (0)2351-41744
E-Mail: werk.luedenscheid@RNA.de

Ergolding branch

Rhein-Nadel Automation GmbH
Ahornstraße 122
D-84030 Ergolding
Tel.: +49 (0)871-72812
E-Mail: werk.ergolding@RNA.de

Remchingen branch

Rhein-Nadel Automation GmbH
Im Hölderle 3
D-75196 Remchingen-Wilferdingen
Tel.: +49 (0)7232-7355-558
E-Mail: werk.remchingen@RNA.de