

Operating Instructions
for
Spring Separator

FE-160S

Table of Contents

1.	Instructions.....	4
2.	Warranty.....	4
3.	Description and technical data	5
4.	Functional description	6
5.	Hazards due to improper use	6
6.	Shipping, handling and storage.....	7
7.	Installation	7
7.1.	Installation.....	8
7.2.	Wiring of spring separator	8
7.3.	Commissioning	8
8.	Maintenance.....	9
9.	Malfunction, fault or damage	9
10.	Dismantling	10
11.	Repairs and spare parts	10



Declaration of Conformity

according to the Low Voltage Directive 2006/95/EC, Machinery Directive 2006/42/EC and
Electromagnetic Compatibility Directive 2004/108/EC

We hereby declare that the product meets the following requirements:
Low-Voltage Directive 2006/95/EC

Applied harmonised standards: DIN EN 60204 T1

Remarks:

We assume that our product will be incorporated into a stationary machine.

Rhein-Nadel-Automation GmbH
Managing Director

Dr. Tobias Hensen



1. Instructions

Notice



This instructions manual has been prepared in accordance with the Machinery Directive 2006/42/EC and its Annexes. The complete contents of the instructions manual must be accessible to all equipment operators. The instructions manual must be kept at the equipment, in a readily accessible place. Be sure to carefully read this instructions manual before initial start-up, and before any intervention on the equipment

Applied standards

- Machine Safety Rules (Official Gazette RS 75/2008), Machinery Directive 2006/42/EC
- Ordinance related to electrical equipment designed for use within certain voltage limits (Official Gazette RS 53/00; 27/2004), Low Voltage Directive 2006/95/EC.
- Regulations on electromagnetic compatibility (Official Gazette RS 132/2006), Electromagnetic Compatibility (EMC) Directive 2004/108/EC.
- SIST EN 61000-6-2 and SIST EN 61000-6-4 Electromagnetic Compatibility
- SIST EN ISO 12100-1 and SIST EN ISO 12100-2 Safety of Machinery
- SIST EN 60204-1 - Electrical Equipment of Machinery

Note to user



For correct installation of this equipment please observe a.m. directives and standards.

Address of customer service provider and spare parts supplier

For customer service requests or spare parts orders please contact: **Rhein-Nadel Automation GmbH**, Reichsweg 19-23, 52068 Aachen, Germany. Notice: This instructions manual is property of Rhein-Nadel Automation GmbH, Aachen/Germany. No part of this instructions manual shall be copied or disclosed to third parties without the knowledge and prior written permission of Rhein-Nadel Automation GmbH.

2. Warranty

This product is covered by a warranty period of 12 months from delivery of the goods (see date of receipt on delivery note).

WARRANTY DECLARATION

As manufacturer of the equipment we warrant that:

1. The equipment will function properly throughout the warranty period, provided that it is used in accordance with the instructions given.
2. Customer services will be provided and spare parts required for repairs delivered within the warranty period.
3. During the warranty period, faults and defects will be remedied at our own cost within no more than 45 days. If the product cannot be repaired before said deadline, we will replace it by a new one at customer's request, or reimburse the purchase price if the product was specially made to customer specifications. The warranty period will be extended by the duration of the repair.

4. Explicitly excluded from this warranty are faults and defects caused by mechanical stress, by inappropriate or improper use or maintenance of the equipment, by a previous, inexpert repair, or by the installation of unsuitable spare parts or faults and defects caused by third-party acts.
5. Minor repairs will be made at customer's premises, major repairs in our workshops.

3. Description and technical data

The spring separator is designed to untangle springs so that they can be used in the downstream process or properly fed to the next device. The spring separator is often used in conjunction with a vibratory feeder or storage hopper which feed entangled springs to the separator, which then feeds the untangled springs to another vibratory feeder for orientation and transfer to downstream processes.

The spring separator comprises a metal enclosure, an electric motor and a rotation plate for disentangling of springs.

The device is designed for connection to a 220 V / 50 Hz power supply.

COMPOSITION:

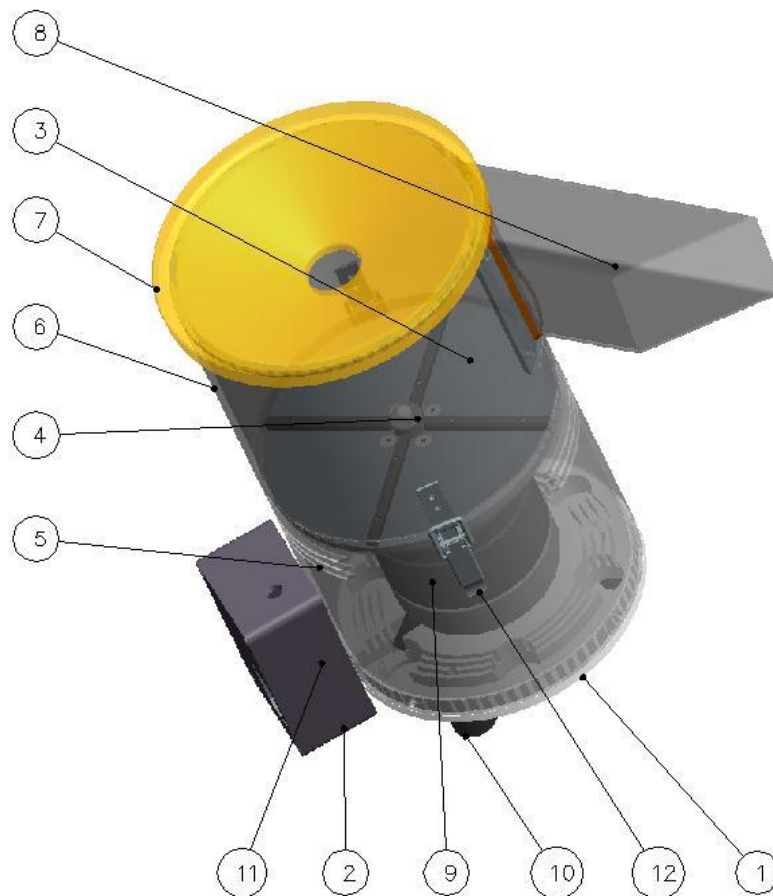

ITEM	DESCRIPTION
1	Baseplate
2	Holder
3	Rotating plate
4	Rotating plate paddles
5	Bottom guard ring
6	Top guard ring
7	Lid
8	Discharge chute
9	Motor
10	Rubber-metal isolator
11	Connecting box
12	Latch

Technical data

	UNIT	SPRING SEPARATOR
Supply voltage	-	220V / 50Hz
Rating	W	90
Nominal current	A	0.4
Speed	r.p.m.	1350
Degree of protection	-	IP54
Temperature	°C	0 - 40
Humidity	%	10 - 90
Weight	kg	12

4. Functional description

The spring separator is connected to a 220 V / 50 Hz power supply.

The spring separator is powered by an electric motor. When entangled springs drop onto the rotating plate they tumble around and progressively become untangled. As the mass of single (separated) springs is lower than the mass of a tangle of springs, the separated springs are ejected via the discharge chute. Normally, the springs are supplied to the separator by means of vibratory feeder or hopper and enter the separator via an opening in the lid.

5. Hazards due to improper use



WARNING:

An electric shock hazard (LIVE CONNECTIONS) exists if operator for various reasons removes the cover of the electrical box without disconnecting power supply first (i.e. without pulling the power cable out of the socket-outlet).



WARNING:

Excessive filling of the separator with springs can lead to malfunctions of, or damage to, the rotating plate or electric motor.



WARNING:

During normal operation, i.e. while using the equipment, it is prohibited to remove the guard ring and lid.

**WARNING:**

Do not use the the spring separator to untangle different spring types simultaneously.

**WARNING:**

Do not perform any maintenance work unless the equipment is isolated from power supply (pull the power cable out of the socket-outlet). Such activities are to be performed only by qualified technicians.

6. Shipping, handling and storage

Pack the spring separator into the wooden box provided for this purpose. Fasten the device to the bottom of the wooden box via three screws and the threaded holes of the rubber-metal isolators.

Avoid shocks and impacts during transport.

Store the equipment in a dry place.

**WARNING:**

Check to make sure that you have received all ordered goods and that they have not been damaged in transit.

**WARNING:**

Check that the data stated on the spring separator rating plate match the specifications of your order.

7. Installation

Before installing the spring separator make sure that the space earmarked for operation of the device is big enough, that the floor has sufficient load bearing capacity, and that in all other respects the site is suitable for operation of the equipment.

- We recommend against installing the device in shops having a relatively high humidity or dusty atmosphere or where metal particles are present.
- There must be sufficient clearance around the equipment for easy maintenance access and unhindered cooling air supply and heat dissipation via the cooling fins.
- The installation surface must be firm and rigid to prevent the propagation of vibrations, which might cause malfunctions of the separator.

**WARNING:**

Be sure to complete the installation work before starting up the separator, i.e. before connecting it to power supply.

**WARNING:**

When installing the spring separator it is mandatory to provide guards in order to prevent access to the device during operation.

7.1. Installation

The spring separator is mounted on three rubber-metal isolators. The bottom faces of these rubber-metal isolators have threaded holes (M6) in them for anchoring the unit to a baseplate. Make sure that the baseplate used for installation of the spring separator is rigid and perfectly level.

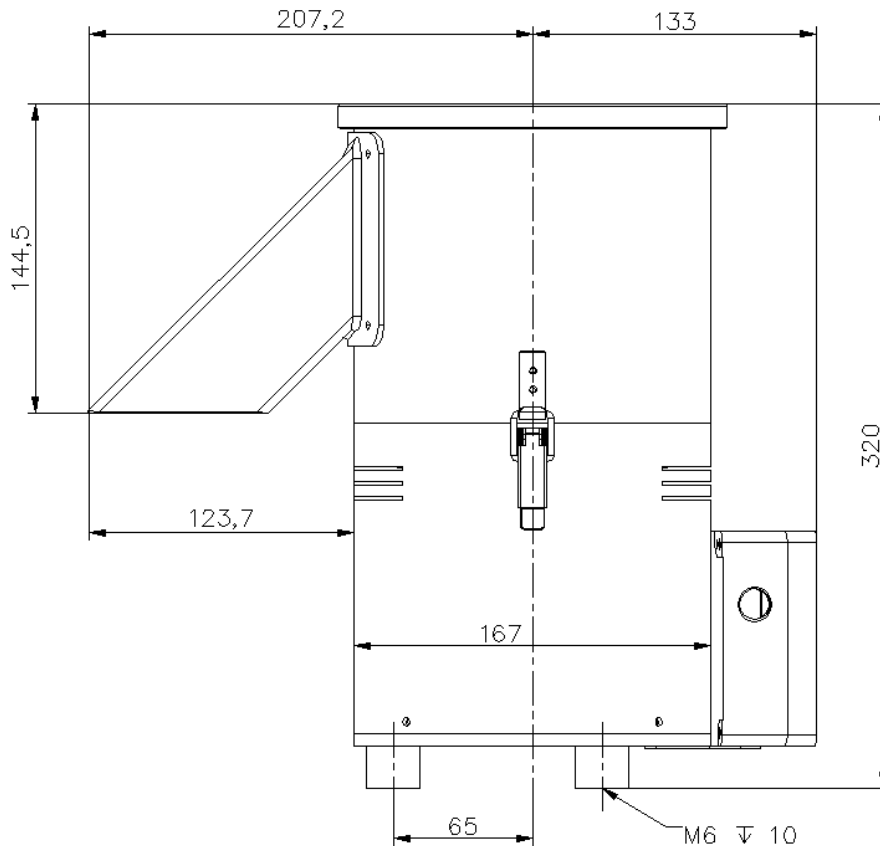

7.2. Wiring of spring separator

The device is supplied by manufacturer with an industrial cable and grounding-type plug.

7.3. Commissioning



WARNING: Take following actions before connecting power supply to the unit:

- The supply voltage must match the voltage specified on the rating plate.
- Proper grounding must be done in accordance with applicable regulations.
- Before putting the spring separator into operation be sure to install it correctly in order to guarantee its safe operation.

When power supply is connected to the device, the latter is turned on and off by switch.



WARNING: Before starting the device make sure that the lid is fitted. After switching off the device be sure to wait until the rotating plate has come to a standstill. Only then is it safe to remove the lid.

8. Maintenance

The spring separator does not require any specific maintenance. Periodic thorough cleaning incl. removal of dust and of all soiling accumulated inside the device is required irrespective of the site of installation. You can clean the device with a compressed air gun after removing the lid, guard ring and rotation plate. Before commencing any cleaning work be sure to disconnect power.



WARNING: Set-up and start-up of the equipment to be done only by qualified technicians.



WARNING: Disconnect power supply before any intervention (pull plug out of socket).



WARNING: While cleaning the equipment with a compressed air gun it is mandatory to wear the prescribed personal protective equipment (safety goggles).

9. Malfunction, fault or damage

Possible causes for reduced performance of the spring separator and troubleshooting instructions are given below.

Possible faults and remedial actions

- Fault:* Separator doesn't work - electric motor is stopped
Remedy: Check power supply and correct function of all electrical components
- Fault:* No springs are discharged via the chute.
Possible cause: too many springs in the separator
Remedy: Adjust the feeding unit so that the correct amount of springs is supplied.

Possible cause: low or high rotating speed of rotation plate
Remedy: Have the separator recalibrated by manufacturer (Rhein-Nadel Automation GmbH)
- Fault:* The springs coming out of the device are still entangled.
Remedy: Have the separator recalibrated by manufacturer (Rhein-Nadel Automation GmbH)
- Fault:* Overheating of spring separator
Possible cause: too little clearance around the device
Remedy: There must be sufficient clearance around the device to permit unhindered air circulation along the cooling fins.
- Fault:* Springs remain stuck in the separator
Possible cause: damaged rotation plate or guard ring, springs get stuck in the gap
Remedy: Replace the rotating plate



WARNING: In case of malfunctions, faults or damage, disconnect power supply at once and call out a qualified technician.

10. Dismantling

The materials used to manufacture the separator can be dismantled and disposed of without problems.

Re-use makes sense for most of the equipment components.

11. Repairs and spare parts

Spring separators are normally manufactured to customers' requirements for different spring types.

Due to the presence of rotating components it is necessary to recalibrate and realign the spring separator following repairs or replacement of aforementioned components. For this reason, all repairs and part replacements should be made by the manufacturer:

Rhein-Nadel Automation GmbH

Reichsweg 19-23

52068 Aachen, Germany

Phone: +49-241-5109 260

E-Mail: vertrieb@rna.de

When ordering spare parts please be sure to state the serial number given on the rating plate.



Headquarters

Rhein-Nadel Automation GmbH
Reichsweg 19-23
D-52068 Aachen
Phone: +49 (0)241-5109-0
E-mail: vertrieb@RNA.de
www.RNA.de

Further RNA group companies:



PSA Zuführtechnik GmbH
Steinackerstraße 7
D-74549 Wolpertshausen
Phone: +49 (0)7904-94336-0
E-mail: info@psa-zt.de
www.psa-zt.de



RNA Automation Ltd.
Unit C Castle Bromwich Business Park
Tameside Drive Birmingham B35 7AG
Great Britain
Phone: +44 (0)121-749-2566
E-Mail: sales@rnaautomation.com
www.rnaautomation.com



HSH Handling Systems AG
Wangenstraße 96
3360 Herzogenbuchsee
Switzerland
Phone: +41 (0)62-956 10-00
E-mail: info@handling-systems.ch
www.handling-systems.ch



RNA Vibrant S.A.
Carrer de l'Energia
08940 Cornellà de Llobregat (Barcelona)
Spain
Phone: +34 (0)93-377-7300
E-mail: info@vibrant-RNA.com
www.vibrant-RNA.com



RNA Digital Solutions GmbH
Reichsweg 19-23
D-52068 Aachen
Phone: +49 (0)1515-99 28 255
E-mail: kontakt@rnadigital.de
www.designforfeeding.com
www.rnadigital.de

Further manufacturing sites of the RNA Group

Lüdenscheid site

Rhein-Nadel Automation GmbH
Nottebohmstraße 57
D-58511 Lüdenscheid
Phone: +49 (0) 2351 -41744
E-mail: werk.luedenscheid@RNA.de

Ergolding site

Rhein-Nadel Automation GmbH
Ahornstraße 122
D-84030 Ergolding
Phone: +49 (0) 871 -72812
E-mail: werk.ergolding@RNA.de

Remchingen site

Rhein-Nadel Automation GmbH
Im Hölderle 3
D-75196 Remchingen-Wilferdingen
Phone: +49 (0)7232-7355-558
E-mail: werk.remchingen@RNA.de